



200 SERIES

Surface Mount

ECCO's surface-mount alarm provides a low-profile warning alarm specifically designed to offer a wide range of mounting options, particularly where space is limited. The reinforced nylon housing provides rugged durability and the epoxy-encapsulated circuit board protects all elements from vibration and moisture. ECCO's unique grill design meets the requirements of SAE J994 for high-pressure washing.

Models

PART NO.	VOLTAGE	dB(A)	AMPS	APPROVALS
210	12	97	0.1	SAE Type C

Features and Benefits

- Designed for mounting in areas where a compact profile is required
- Universal mounting bracket covers a wide range of popular mounting applications
- Temperature Range: -40°F to +185°F (-40°C to +85°C)
- 2 Year Warranty

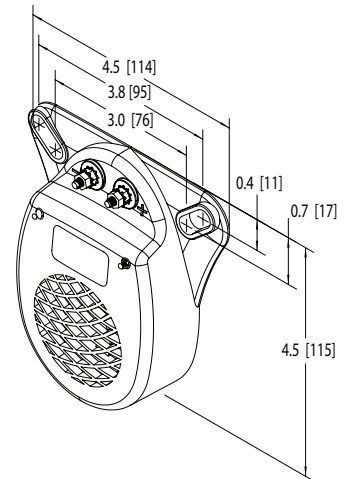

Alarm Specifications

Connection: 18-32 uni stud connection
 Fiberglass reinforced nylon housing
 Recommended mounting bolt: 5/16" Grade 5
 Recommended washer: 5/16" Type A, Series N or W
 Recommended mounting torque: 156 in. lbs.

Need to find an alarm? There's an app for that.

Scan the QR Code to learn how or search ECCO Mobile in your app store.

