

# WOLO®

## MIGHTY MO™ Model 390-24 • 24-VOLT INSTALLATION INSTRUCTIONS



Your purchase of Wolo's MIGHTY MO is the perfect choice when a loud horn is needed in a noisy environment. This product is manufactured with the finest materials and the latest technology. Each horn is tested to meet our high standards, to ensure that it will function perfectly when a powerful warning signal is needed. Our quality workmanship and components are Wolo's assurance that this product will provide years of dependable service. If you need help using or installing your new Wolo horn, our technicians are available to answer your questions, Monday thru Friday, from 9 AM to 4 PM EST at 888-550-4676.

### IMPORTANT MESSAGE BEFORE INSTALLATION IS STARTED

Before installation is attempted, it is important to read these instructions completely. The lives of people are dependent on the proper installation. The person installing this horn must have knowledge of the correct method of installing a horn to industrial equipment or a truck, as well as knowledge of the vehicle's electrical system.

- **IMPORTANT:** The installer must carefully inspect both sides of any location that will require drilling to ensure that there are no components, wires and or any vehicle parts that could be damaged when drilling.
- **IMPORTANT:** Always de-burr any drilled holes to ensure that there are no sharp edges. Install a rubber grommet into all metal holes that the wires are being routed through, one (1) rubber grommet provided.
- **WARNING:** If the vehicle is equipped with air bags, always refer to the vehicle's shop manual for the deployment location of the air bags. Never install the horn switch, wires and/or components in the deployment area of any air bag. Improper installation could reduce the effectiveness of the vehicle's air bag system and/or project an object that could cause serious personal injury or death to the driver or passenger. The user/installer assumes all responsibility to properly access a safe mounting location for the horn switch to provide ultimate safety to the driver and passengers inside the vehicle.
- **WARNING:** Always use proper OSHA approved ear protection to prevent damage or loss of hearing.
- Again, read this manual completely and note any messages marked "**IMPORTANT**" or "**WARNING**". A safe installation will prevent serious injury or damage to the vehicle.

### MOUNTING: Fig. 1

**IMPORTANT:** For best performance results from your Mighty Mo horn take note of the important notations listed below.

**IMPORTANT:** The horn is secured to the mounting location using the two (2) standoff metal tubes, see Fig.1. Never secure horn using the tabs on the horn's die cast housing. The tabs are not designed to withstand high vibration.

**IMPORTANT:** The bottom of the horn should not be touching the mounting surface. The horn bottom has to be unrestricted to be able to freely vibrate to produce the correct sound.

**IMPORTANT:** If the horn is mounted horizontally and will be exposed to weather conditions, the front of the horn should be positioned with a slight tilt to prevent water from entering the trumpet which could cause a premature failure.

**WARNING:** To prevent damage to the vehicle or electrical shock, don't connect the horn's power plug until instructed to do so.

1. **NOTE: This step aids in determining a correct mounting location.** Attach the two standoff tubes to the horn's mounting bracket using the bolts provided. Hand tighten the nuts to the bolts (no need to use the flat washer and lock washer for this step, they will be used later). Position the horn in the desired location, check all clearances. Mark the position of the head of each mounting bolt to assist you in locating where to drill the mounting holes.

**NOTE:** as a reference, the mounting hole locations should be spaced 10-3/4" on center. Drill mounting holes to size 9/16".

2. Remove standoff tubes and proceed to securely mount horn as shown below in Fig. 1.

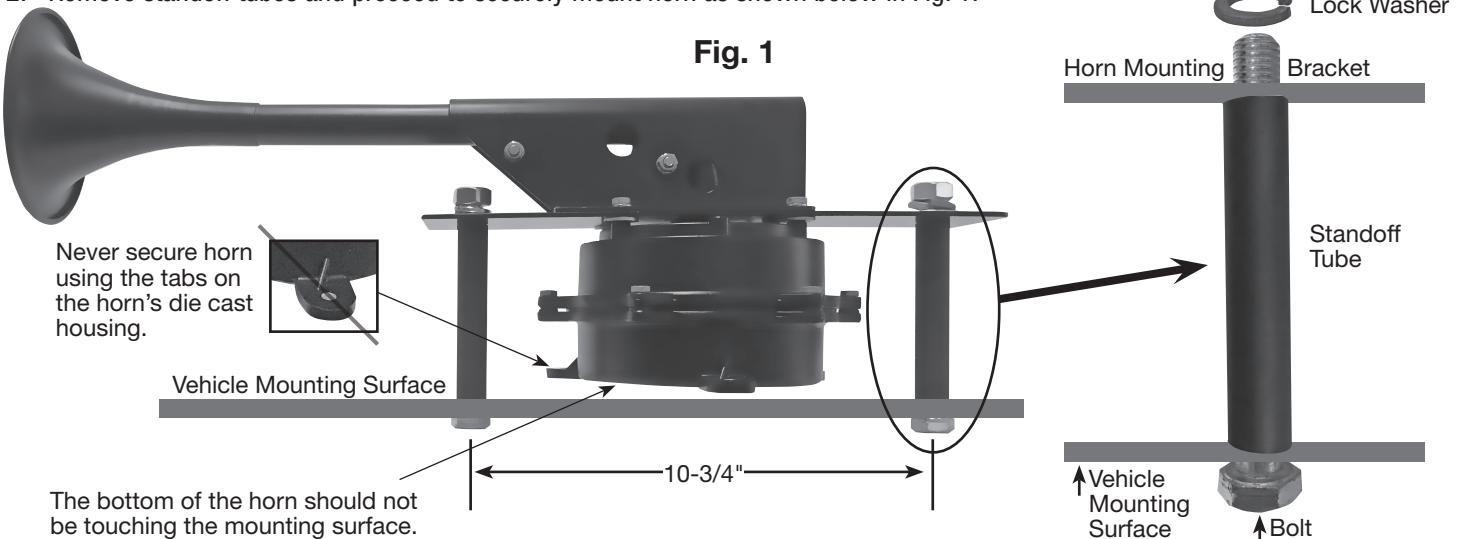

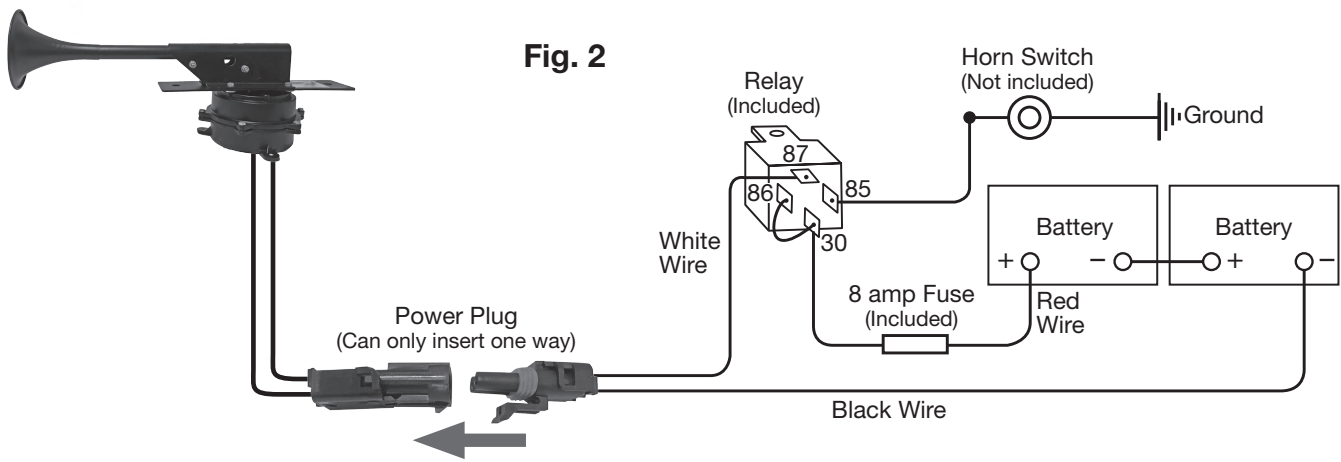

**Fig. 2**

## WIRING: FIG. 2

**IMPORTANT:** Don't connect the power plug to the horn until instructed

**IMPORTANT:** Wolo recommends that the relay provided be used unless equipment the horn is being mounted to already has a relay in the horn circuit.

### ELECTRICAL CONNECTIONS FOR USING A NEW HORN BUTTON SWITCH

3. Install the relay provided near to the horn and in a dry location with the terminals facing downward to prevent water from entering into the case of the relay.
4. Connect relay terminal 87 to the power plug's white wire. If the length of the white wire needs to be extended use stranded 16-gauge or heavier.
5. Connect relay terminal 85 to the horn button switch (horn switch not provided).
6. The horn button switch's other terminal or wire is connected to ground, any metal body bolt that is clean of paint and rust.
7. Connect relay terminal 30 and 86 to positive (+)24-volts such as battery, alternator, etc. using the 8-amp inline fuse provided. Use 16-gauge wire or heavier. Protect the electrical circuit with the eight (8)-amp fuse (provided). If the length of the fuse wire needs to be extended, use 16-gauge stranded wire or heavier wire.

**IMPORTANT:** Make sure all wires are securely fastened to vehicle using plastic wire ties or electrical tape (not provided).

**WARNING:** If horn wires were routed in the dashboard area, carefully inspect the under dash area to make sure the horn wires or the vehicle's electrical system wires are not interfering with the operation of vehicle's controls; accelerator, brake, clutch pedals and etc.

8. Installation is complete; connect the power plug and test horn.

## Warranty

Wolo Manufacturing Corporation ("Wolo") warrants to the original purchaser, for three months from the date of purchase, that this product is free from defects in workmanship and materials. If there is such a proven defect, Wolo, at its option, will either repair or replace the item free of charge, if it is returned to Wolo within three months from the date of purchase together with proof of purchase as described below. Wolo reserves the right to inspect any defect prior to settling any warranty claim by repair or replacement. This warranty is limited as above provided and Wolo will not be responsible for fire or other casualty or accident, due to neglect, abuse, abnormal use, modifications, faulty installation of this product, or natural causes.

ANY EXPRESSED WARRANTY NOT PROVIDED HEREIN IS EXCLUDED AND DISCLAIMED. THE IMPLIED WARRANTIES OF MERCHANTABILITY AND OF FITNESS FOR A PARTICULAR PURPOSE ARE EXPRESSLY LIMITED TO A TERM OF THREE (3) MONTHS. UNDER NO CIRCUMSTANCES SHALL WOLO BE LIABLE TO PURCHASER OR ANY OTHER PERSON FOR ANY SPECIAL OR CONSEQUENTIAL DAMAGES, WHETHER ARISING OUT OF BREACH OF WARRANTY OR OTHERWISE.

To obtain warranty service, return the product prepaid, and include the original bill of sale showing the date of purchase. Provide with the return a brief description of the problem with a daytime telephone number. Also, include with the return a check or money order in the amount of \$20.00 to cover return shipping.

Mail to:

**Wolo Manufacturing Corp.**  
Attn: Warranty Service  
One Saxwood Street, Deer Park, NY 11729  
E-mail: tech@wolo-mfg.com