

INSTALLATION INSTRUCTIONS

Model 125 and 1125 DOMINATOR

Your choice of a Wolo horn is a perfect choice to compliment your vessel or vehicle. Wolo horn's are manufactured with the finest quality materials and every horn is inspected and tested before being packaged. Precision workmanship and quality components will assure years of dependable service. If you need help installing your new Wolo horn, or have any questions, our technicians are available to answer your questions, Monday through Friday from 9 AM to 4 PM EST at 1-888-550-HORN (4676)

MOUNTING

1. Locate the desired area you wish to mount the Dominator Horn. For best results, the front of the horn should be unobstructed so that the horn's sound can project straight ahead. Use the horn's gasket as a template, mark hole locations and drill to size. (See Fig. A.)

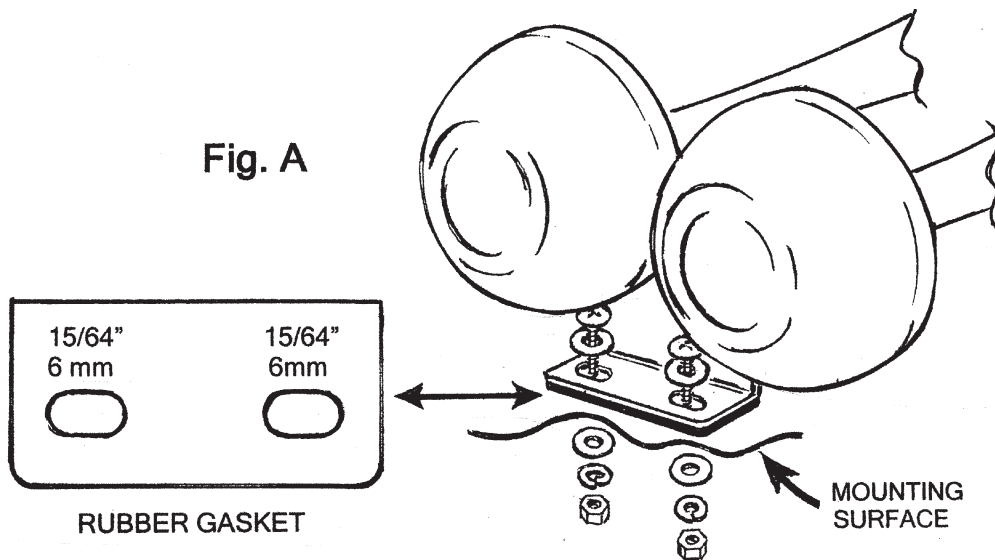

2. Mark the wire hole location if the horn's wire is going to pass through the mounting surface and drill to size. (See Fig. C)

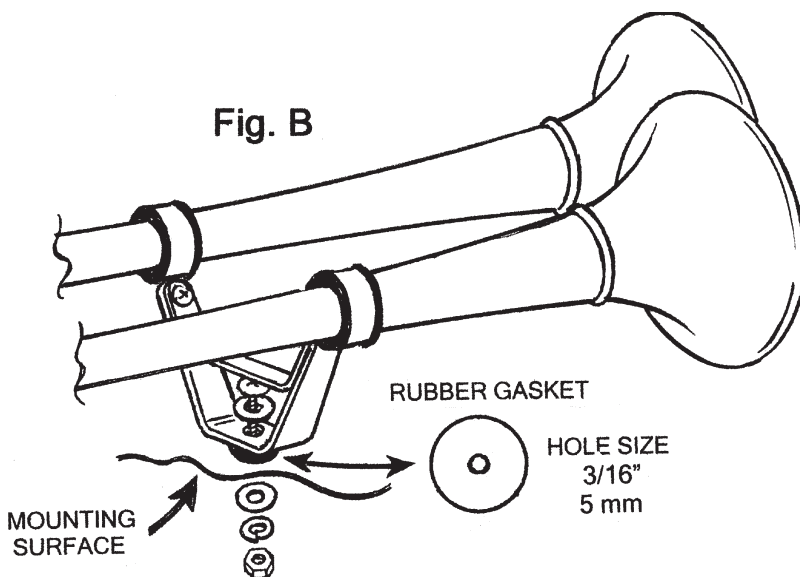

IMPORTANT: Make sure the hole is free of any burrs that could cut into the horn's wire. For roof mount mounting, to prevent water leaks, it is recommended that silicon or a waterproof sealer be placed on the wire at the point of entry into the roof.

3. Secure the horn using the hardware provided. Tighten screws evenly to prevent damage to the horn. (See Fig. A.) **IMPORTANT:** Be sure to use the rubber gasket to protect against water leaks.
4. Push the front bracket forward until it is tight. Use the bracket as a template, mark hole location and drill to size. (See Fig. B.)
5. Secure the front trumpet bracket to the location using the hardware provided. Tighten screw evenly. **IMPORTANT:** Be sure to use the rubber gasket to protect against water leaks.

WIRING

WIRING to New Horn Button Switch (See Fig. C)

6. Connect one wire from each horn to (+) 12-volts positive, the battery, alternator, etc. A 8 amp inline fuse should be used (not included).
7. Connect the horn switch (not provided) to the other black wire of each horn.
8. Connect the horn switch's other wire to ground, under any metal bolt that is clean of paint and rust.

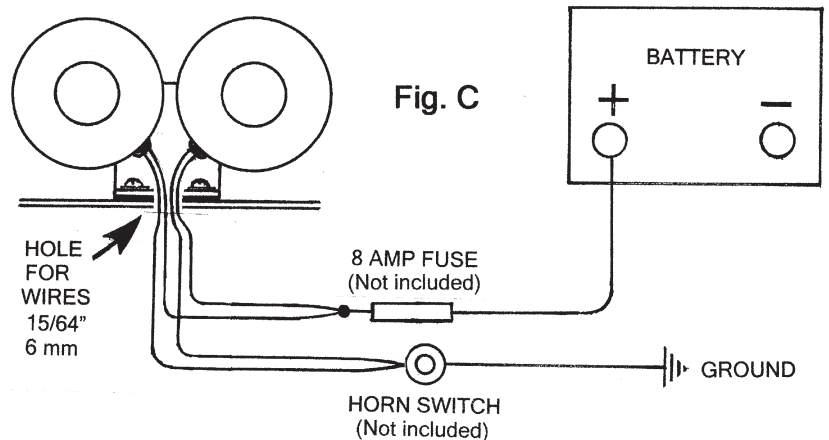

WIRING to Factory Horn System With Two (2) Wires (See Fig. D)

9. If the factory horn has two wire terminals, remove the wires from the factory horn and connect one wire to each of The Dominator horns. Installation is complete.

WIRING to Factory Horn System With One (1) Wire (See Fig. E)

10. If the factory horn has one wire terminal, remove the wire from the factory horn and connect to one wire of each of The Dominator horns.
11. The other horn wire from each of The Dominator horns is connected to ground, under any metal bolt that is clean of paint and rust. Installation is complete.

IMPORTANT: Make sure all wires are secured and connections are properly taped.

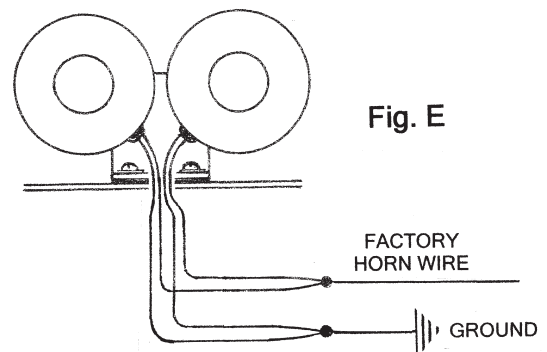
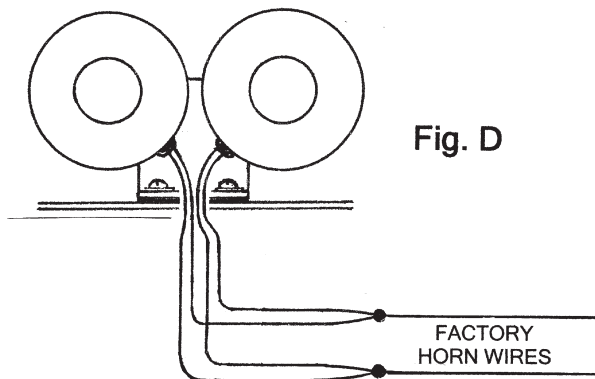

WARRANTY

Wolo Manufacturing Corporation ("Wolo") warranties to the original purchaser, for three months from the date of purchase, that this product is free from defects in workmanship and materials. If there is such a proven defect, Wolo, at its option, will either repair or replace the item free of charge, if it is returned to Wolo within three months from the date of purchase together with proof of purchase as described below. Wolo reserves the right to inspect any defect prior to settling any warranty claim by repair or replacement. This warranty is limited as above provided and Wolo will not be responsible for fire or other casualty or accident, due to neglect, abuse, abnormal use, modifications, faulty installation of this product, or natural causes.

ANY EXPRESSED WARRANTY NOT PROVIDED HEREIN IS EXCLUDED AND DISCLAIMED. THE IMPLIED WARRANTIES OF MERCHANTABILITY AND OF FITNESS FOR A PARTICULAR PURPOSE ARE EXPRESSLY LIMITED TO A TERM OF THREE (3) MONTHS. UNDER NO CIRCUMSTANCES SHALL WOLO BE LIABLE TO PURCHASER OR ANY OTHER PERSON FOR ANY SPECIAL OR CONSEQUENTIAL DAMAGES, WHETHER ARISING OUT OF BREACH OF WARRANTY OR OTHERWISE.

To obtain warranty service, return the product prepaid, and include the original bill of sale showing the date of purchase. Provide with the return a brief description of the problem. Also, include with the return a check or money order in the amount of \$10.00 to cover return shipping. Mail to:

Wolo Manufacturing Corp. • One Saxwood Street, Deer Park, NY 11729
Attn: Warranty Service
E-mail: tech@wolo-mfg.com