



INSTALLATION INSTRUCTIONS

Model 140-24 & 145-24 SEA ALERT® 24-Volt

Your purchase of a Wolo SEA ALERT® Air Horn will complement your boat, while offering an extra level of protection. Wolo's products are manufactured with the finest materials. Before being packaged, each horn is tested to ensure it meets all of our manufacturing specifications. If you need help installing your new Wolo horn, our technicians are available to answer your questions, Monday thru Friday, 9 AM to 4 PM EST at 1-888-550-HORN (4676).

Before installation of the horn is attempted, it is important to read these instructions completely. The lives of people can be dependent on a proper installation of the horn. The person doing the installation must have knowledge of the proper method for mounting and securing the horn to the exterior of the boat, as well as knowledge of the boat's electrical system. Again, read the instructions completely and note any messages marked "IMPORTANT" or "WARNING". A safe installation will prevent injury or damage to the boat.

WARNING: Installation of the SEA ALERT requires drilling. The installer must carefully inspect both sides of the selected mounting locations to ensure that there are no wires, fuel lines and or any other components that could be damaged by drilling.

WARNING: If any wires are routed through drilled holes, always de-burr ensuring that there are no sharp edges. Install a rubber grommet into all metal holes that wires are being routed through.

MOUNTING TRUMPET: Fig. 1 & 2

IMPORTANT: The horn should be mounted facing forward whenever possible. The NMMA Certification Program requires this for boats 39' or longer.

1. Locate the desired mounting location of the trumpet.
For best results, the front of the horn should be unobstructed so that the sound can carry straight ahead.

IMPORTANT: FOR BEST PERFORMANCE AND SOUND, ALWAYS MOUNT THE COMPRESSOR CLOSE TO TRUMPET, KEEPING THE HOSE LENGTH AS SHORT AS POSSIBLE. THE COMPRESSOR MUST BE MOUNTED IN A DRY INTERIOR LOCATION).

2. Use the horn's gasket as a template, mark hole locations and drill to size.

3. Thread the chrome air inlet tube into the base of the horn.

4. Mount and secure the horn as shown in Fig. 1.

IMPORTANT: Be sure to use the provided rubber gasket to protect against water leaks. Tighten the base plate front screw and rear nut that threads onto the air inlet tube evenly to ensure a watertight seal.

5. Position the front trumpet support bracket around the narrow part of the trumpet. **IMPORTANT:** Provided in the kit is a soft rubber strip that is placed into the ring of the support bracket to provide a tight fit and prevent vibration. Push the bracket forward until it is tight. Use the bracket as a template, mark hole locations and drill to size. See Fig 2.

6. **Secure the front trumpet support bracket using the hardware provided. Tighten screws evenly to ensure a watertight seal. IMPORTANT: Be sure to use the rubber gasket provided to protect against water leaks.**

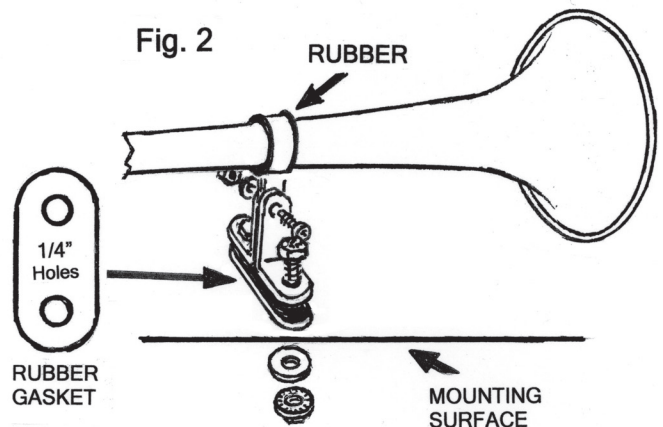
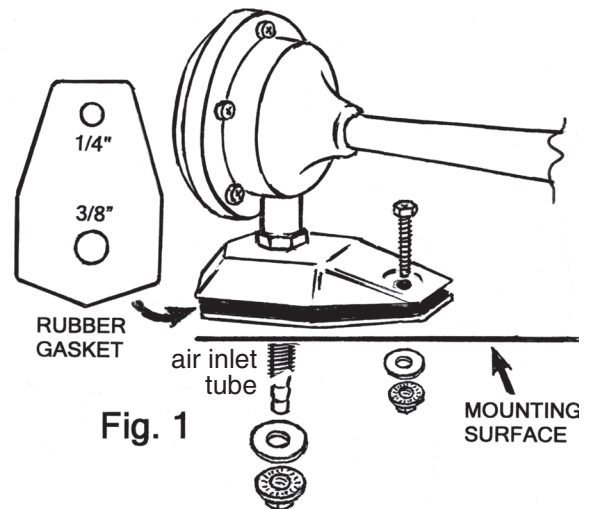

COMPRESSOR INSTALLATION: Fig. 3 & 4

7. Install the compressor in a dry interior location. **IMPORTANT:** The compressor should not be mounted further than 30 inches from the trumpet to ensure best sound.

8. To secure the compressor, drill one 3/16" hole. When possible, mount the compressor vertically (air outlet on top). Install the head of the bolt into the mounting bracket's slot on the side of the compressor. Secure the compressor using the lock washer/nut provided as shown in Fig. 3.

9. Using the plastic tubing provided, cut to size and connect the compressor to the horn's air inlet tube as shown in Fig. 4.

WARNING: Avoid making any kinks or sharp bends in plastic tubing that can reduce air flow and alter the horn's sound. For best performance and sound, always keep the plastic tubing as short as possible.

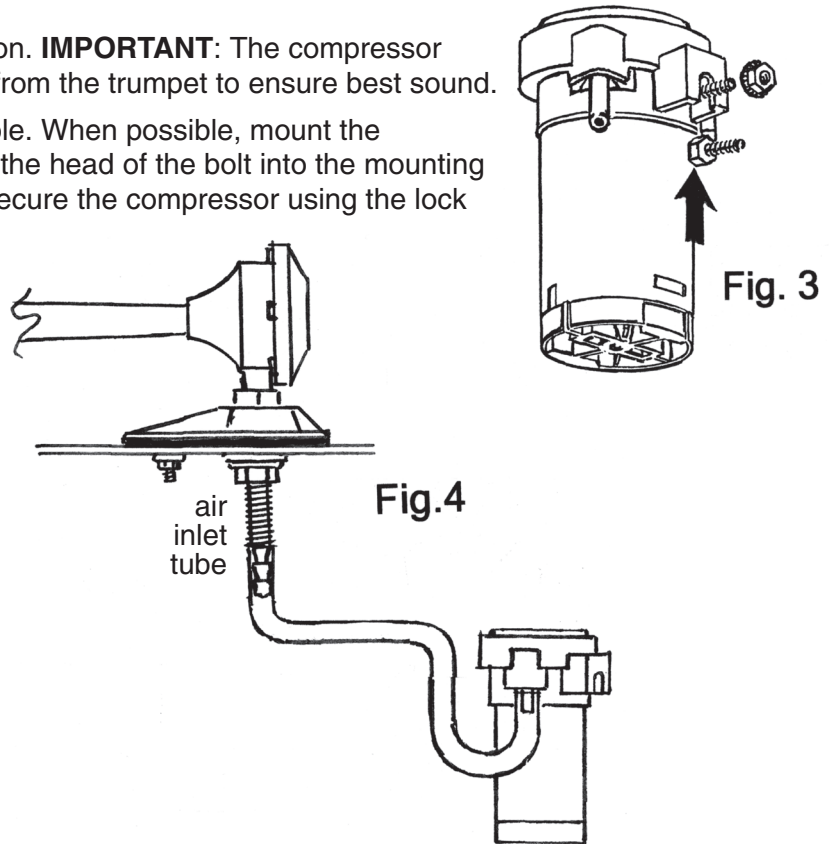

WIRING:

ELECTRICAL CONNECTIONS FOR USING A NEW HORN BUTTON SWITCH Fig. 5

10. Install the horn relay provided, locate close to the compressor in a dry interior location with the terminals facing downward.

11. Connect relay terminal 87 to the compressor's positive (+) terminal. Use 16-gauge wire or heavier.

12. Connect relay terminal 85 to the horn button switch terminal. (Horn switch not provided).

13. The horn switch's other terminal is connected to negative (-) such as the (-) battery post battery post or any clean metal negative surface. Use 18 gauge wire or heavier.

14. Connect relay terminal 30 & 86 to positive (+) 24-volts such as battery, alternator, fuse block or etc., using 16-gauge wire or heavier. **IMPORTANT:** Protect the electrical circuit with the fifteen (15)-amp inline fuse provided. **WARNING:** The inline fuse provided must be connected directly to the power source.

15. Connect the compressor's negative (-) terminal to boat's negative (-) battery post or any clean metal negative surface. Use not less than 16-gauge wire.

RECAP OF RELAY TERMINAL CONNECTIONS

Relay terminals 30 & 86: the two terminals are connected to 24-volts (+) positive, using the 15-amp inline fuse.

Relay terminal 85: is connected to horn switch.

The horn switch's other terminal: is connected to negative (-) battery post.

Relay terminal 87: is connected to the compressor's (+) motor terminal.

The compressor's negative (-) terminal is connected the boat's negative (-) battery post.

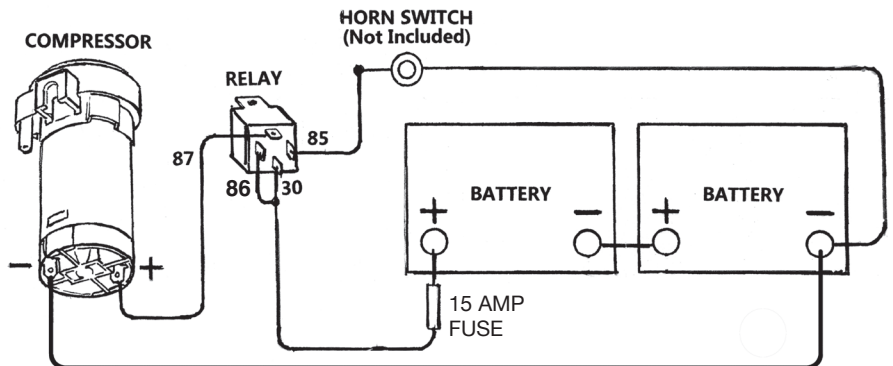

WIRING:

USING BOATS FACTORY HORN SYSTEM (TWO WIRE SYSTEM) Fig. 6

WARNING: You are required to use the relay supplied with this horn kit to protect the factory horn button switch and wiring. The original factory horn draws less amperage than your new Sea Alert air horn. The relay will ensure that the horn works reliably and will protect the factory horn system.

Fig. 6

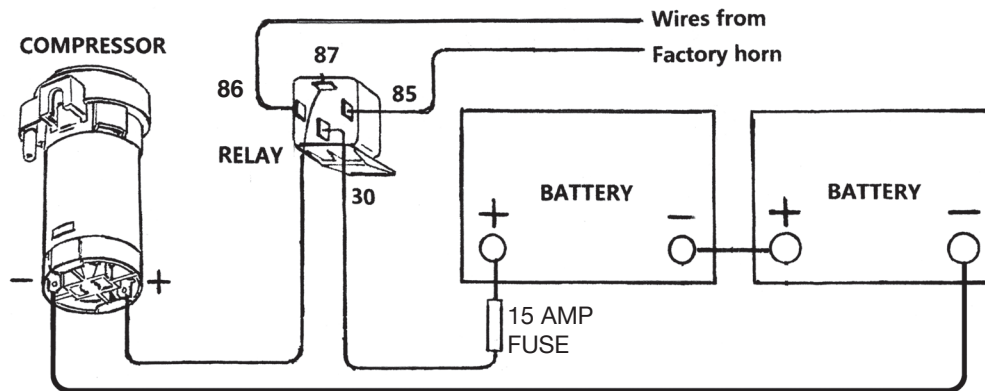

16. Remove the two (2) wires connected to factory horn.
17. Connect relay terminal 85 to one of the factory horn wires. Note: It does not make a difference which factory horn wire is connected to terminal 85.
18. Connect relay terminal 86 to the other factory horn wire.
19. Connect relay terminal 30 to positive (+) 24-volts such as the battery, alternator or fuse block, using 16-gauge or heavier wire. **WARNING:** The 15-amp inline fuse provided must be connected directly to the power source.
20. Connect relay terminal 87 to the compressor's positive (+) terminal. Use not less than 16-gauge wire.
21. Connect the compressor's negative (-) terminal to boat's negative (-) battery post or any clean metal negative surface. Use not less than 16-gauge wire.

RECAP OF RELAY TERMINAL CONNECTIONS

Relay terminal 30: connected to 24-volts (+) positive, using the 15-amp inline fuse.

Relay terminal 85: is connected to one of the factory horn wires.

Relay terminal 86: is connected to the other factory horn wire.

Relay terminal 87: is connected to the compressor's (+) motor terminal.

The compressor's negative (-) terminal is connected the boat's negative (-) battery post.

WARNING: ALWAYS TEST THE HORN SIGNAL SYSTEM BEFORE USING THE VESSEL TO ENSURE THE HORN IS FUNCTIONING AT PEAK PERFORMANCE. YOUR LIFE AND THE LIVES OF PEOPLE ARE DEPENDENT ON THE VESSEL HAVING A WORKING HORN SIGNAL SYSTEM. NEVER USE THE VESSEL WITHOUT A WORKING HORN SYSTEM.

This horn meets the following standards:

Meets the U.S. Coast Guard's C.O.L.R.E.G.S. and U.S. Inland Navigation Rules, Annex III Regulations for boats up to 20 meters / 65 ft.



This horn is National Marine Manufacturers Association (NMMA) "type accepted"



Meets the American Boat & Yacht Council (ABYC) A-23 standard for boats up to 20 meters / 65 ft.

WARRANTY

Wolo Manufacturing Corporation ("Wolo") warranties to the original purchaser, for twelve months from the date of purchase, that this product is free from defects in workmanship and materials. If there is such a proven defect, Wolo, at its option, will either repair or replace the item free of charge, if it is returned to Wolo within twelve months from the date of purchase together with proof of purchase as described below. Wolo reserves the right to inspect any defect prior to settling any warranty claim by repair or replacement. This warranty is limited as above provided and Wolo will not be responsible for fire or other casualty or accident, due to neglect, abuse, abnormal use, modifications, faulty installation of this product, or natural causes.

ANY EXPRESSED WARRANTY NOT PROVIDED HEREIN IS EXCLUDED AND DISCLAIMED. THE IMPLIED WARRANTIES OF MERCHANTABILITY AND OF FITNESS FOR A PARTICULAR PURPOSE ARE EXPRESSLY LIMITED TO A TERM OF TWELVE (12) MONTHS. UNDER NO CIRCUMSTANCES SHALL WOLO BE LIABLE TO PURCHASER OR ANY OTHER PERSON FOR ANY SPECIAL OR CONSEQUENTIAL DAMAGES, WHETHER ARISING OUT OF BREACH OF WARRANTY OR OTHERWISE.

To obtain warranty service, return the product prepaid, and include the original bill of sale showing the date of purchase. Provide with the return a brief description of the problem. Also, include with the return a check or money order in the amount of \$10.00 to cover return shipping. Mail to:

Wolo Manufacturing Corp.
One Saxwood Street, Deer Park, NY 11729
Attn: Warranty Service
E-mail: tech@wolo-mfg.com