



MODEL 308-2T

SONIC BLAST™

Installation Instructions

Your purchase of a Wolo **SONIC BLAST** is a perfect choice to compliment your vehicle. Wolo's products are manufactured with the finest materials. Each horn is tested to ensure it meets all of our manufacturing specifications, before it is packaged. If you need help installing this product, our technicians are available to answer your questions, Monday through Friday from 9 AM to 4 PM EST by calling 1-888-550-HORN (4676) United States and Canada.

MOUNTING FIG. #1

1. Remove the factory horn, and install your new **SONIC BLAST** horn in the same position or a preferred location.
IMPORTANT: The horn's front grill should be slightly angled facing downward to prevent water and dirt from entering into the horn.
2. Drill mounting hole to size 5/16" if required.
3. Secure each horn to the vehicle using the hardware provided. **IMPORTANT:** To get the proper sound, only use the mounting bracket provided with the horn. (See Fig. 1)

Fig. 1

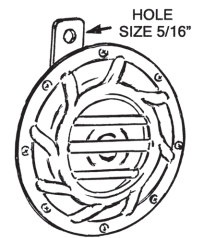

IMPORTANT: For one (1) terminal factory horn system, the grounding jumper wire provided needs to be secured under the mounting bolt before securing the horn to a metal body ground surface. See Fig. 3.

WIRING:

TWO (2) TERMINAL WIRING FIG. #2

4. For vehicles where the factory 12-volt horn wires connect to two (2) horn terminals, simply transfer the factory horn wires to each new Wolo horn. It doesn't make a difference which horn terminals are used on your new Wolo horn when transferring the wires from your factory horn. **IMPORTANT:** Always make sure that there is a 10-amp fuse used in the horn circuit to protect the vehicle. If the wire terminals that were connected to your vehicle's factory horn are not the same as your new Wolo horn, provided in the kit are 1/4" female push-on insulated terminals. The installation is complete and the horn is ready to be used.

Fig. 2

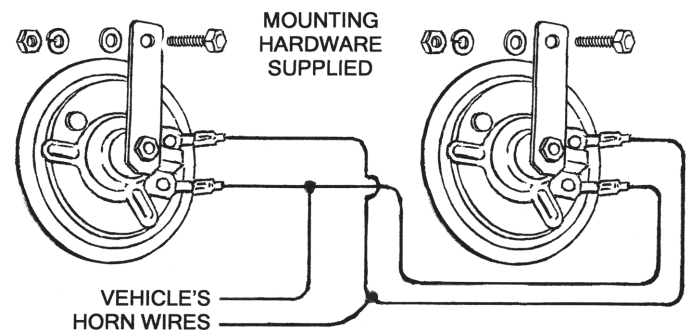

ONE (1) TERMINAL WIRING FIG. #3

5. For vehicles where the factory 12-volt horn wire connects to only one (1) horn terminal. Transfer the factory horn wire to one terminal of each new Wolo horn. It doesn't make a difference which horn terminal is used when transferring the wire from your factory horn.
6. Using the grounding wires supplied, place the loop end under the mounting bolt of the horn and firmly tighten. Make sure the horn's mounting bracket is secured to a metal body surface that is clean of paint and rust.
7. Attach the ground wire's female 1/4" push-on terminal to the horn's unused terminal, repeat process for the other new Wolo horn.

Fig. 3

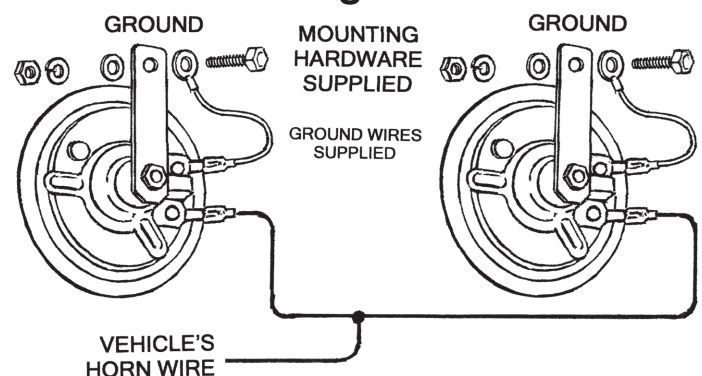

IMPORTANT: Always make sure that there is a 10-amp fuse used in the horn circuit to protect the vehicle. If the wire terminal that was connected to your vehicle's factory horn is not the same as your new

Wolo horn, provided in the kit are 1/4" female push-on insulated terminals. The installation is complete and the horn is ready to be used.

WARRANTY

Wolo Manufacturing Corporation ("Wolo") warranties to the original purchaser, for three months from the date of purchase, that this product is free from defects in workmanship and materials. If there is such a proven defect, Wolo, at its option, will either repair or replace the item free of charge, if it is returned to Wolo within three months from the date of purchase together with proof of purchase as described below. Wolo reserves the right to inspect any defect prior to settling any warranty claim by repair or replacement. This warranty is limited as above provided and Wolo will not be responsible for fire or other casualty or accident, due to neglect, abuse, abnormal use, modifications, faulty installation of this product, or natural causes.

ANY EXPRESSED WARRANTY NOT PROVIDED HEREIN IS EXCLUDED AND DISCLAIMED. THE IMPLIED WARRANTIES OF MERCHANTABILITY AND OF FITNESS FOR A PARTICULAR PURPOSE ARE EXPRESSLY LIMITED TO A TERM OF THREE (3) MONTHS. UNDER NO CIRCUMSTANCES SHALL WOLO BE LIABLE TO PURCHASER OR ANY OTHER PERSON FOR ANY SPECIAL OR CONSEQUENTIAL DAMAGES, WHETHER ARISING OUT OF BREACH OF WARRANTY OR OTHERWISE.

To obtain warranty service in the United States, return the product prepaid, and include the original bill of sale showing the date of purchase. Provide with the return a brief description of the problem. Also, include with the return a check or money order in the amount of \$10.00 to cover return shipping.

Mail to:

Wolo Manufacturing Corp. • One Saxwood Street, Deer Park, NY 11729 Attn: Warranty Service E-mail: tech@wolo-mfg.com

© 2014 Wolo Mfg. Corp. All Rights Reserved