

INSTALLATION INSTRUCTIONS

For Model 416 Euro Hi/Lo Horn

The addition of a Wolo horn kit in your vehicle will provide an extra level of sound. The Wolo name, with more than twenty years experience, is your guarantee of a superior horn product. If you need help installing your new Wolo horn, our technicians are available to answer your questions, Monday thru Friday, from 9 AM to 4 PM EST at 1-888-550-HORN (4676).

1. Install the compressor in the engine compartment in a dry location and safe from engine and exhaust manifold heat. The compressor must be mounted on a metal body surface. **If your compressor is not bolted to metal**, use a piece of 16-gauge wire and connect one end under mounting bolt, and ground other end under any metal body bolt that is clean of print and rust. Compressor must be grounded. (See Figure 1).

2. To secure the compressor, drill a 3/16-inch hole. Mount the compressor vertically (air outlets on top). Install the head of the bolt into the slot on the compressor's housing. Secure the compressor to the vehicle using the lock washer/nut provided (Figure 1).

3. Position each trumpet with open end facing down, mark and drill a 1/4-inch hole for each trumpet. Secure to vehicle referring to Figure 2. Use mounting hardware in order shown – spacer, lock washer/nut.

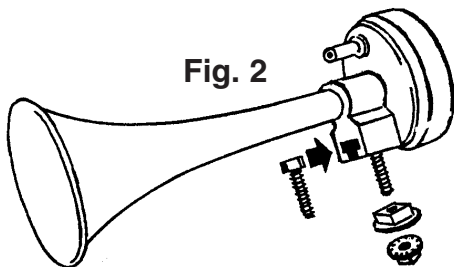

4. **IMPORTANT:** Mount trumpets with the open ends facing down. This will prevent water from entering into the trumpets and compressor. **Water damage to the horn's component parts is not covered by our factory warranty.**

5. Using plastic air tubing included in the kit, cut to proper length and install referring to Figure 3. **CAUTION:** Avoid making any kinks or sharp bend in tubing that will restrict the airflow and alter the horn's sound.

ELECTRICAL CONNECTIONS USING VEHICLE'S FACTORY HORN SWITCH

A. **For two (2) wire systems:** If vehicle's factory horn has two (2) terminals, simply transfer the wires to the compressor's terminals. **IMPORTANT:** when testing the horns, if compressor motor turns on but the horn does not sound, reverse the wires connected at the bottom of the compressor.

B. **For one (1) wire system:** If vehicle's factory horn has one (1) terminal simply transfer wire to the compressor's positive (+) terminal. The compressor's negative terminal is connected to any metal body ground. Connection should be free of rust or paint.

Put a few drops of Light oil (SAE-10) into the hole on Compressor marked "Oil" every 6 months

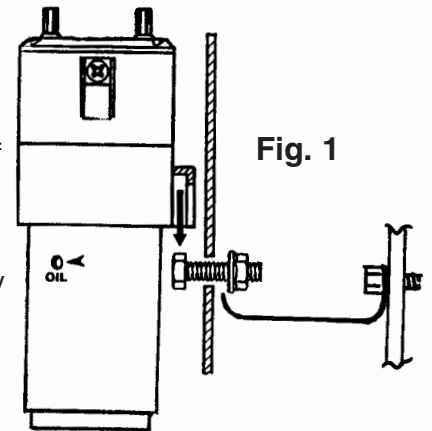

Fig. 1

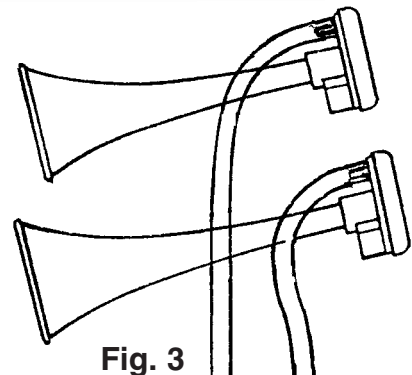
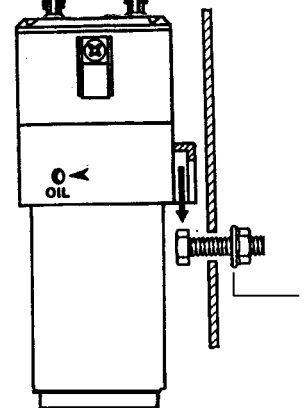

Fig. 3



ELECTRICAL CONNECTIONS FOR A NEW HORN BUTTON SWITCH:

Install the relay in a dry location with the terminals facing downward near the compressor. Refer to Figure 4 for wiring.

- A. Connect relay terminal 87 to the positive terminal at the bottom of the compressor. Use no less than a 16-gauge wire.
- B. Connect relay terminal 85 to the horn switch terminal. The other horn switch terminal is connected to ground (body of vehicle). An 18-gauge wire is suggested for this connection.
- C. Connect relay terminals 30/86 to positive (+) 12-volt battery, alternator or accessories. Use 16-gauge or heavier wire. A 20-ampere fuse is suggested to be installed as shown in Figure D.

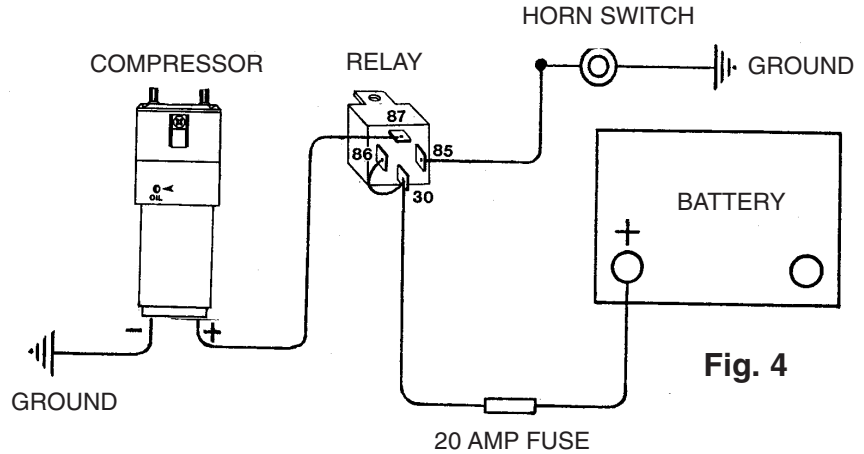

RECAP OF TERMINAL CONNECTIONS

- Terminals 30/86: the two (2) terminals are connected to 12-volt positive (+) using a fuse.
- Terminal 85: connect horn switch negative (-).
- Terminal 87: connect positive (+) terminal of compressor.

TOGGLE SWITCH INSTALLATION

The toggle switch included in kit, will control the horn's tone: Steady Tones / Euro Hi-Lo Tone.

- A. Mount the toggle switch in an accessible place inside the vehicle.
- B. One terminal of the toggle switch is connected to the compressor's side terminal. Use insulated terminal provided to make connection (Figure 5).
- C. The other toggle switch terminal is connected to the positive (+) terminal at the bottom of the compressor. (Figure 5)

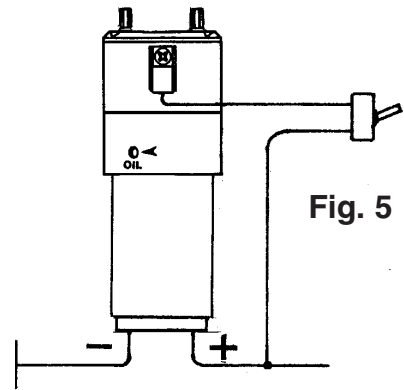

Warranty

Wolo Manufacturing Corporation ("Wolo") warranties to the original purchaser, for three months from the date of purchase, that this product is free from defects in workmanship and materials. If there is such a proven defect, Wolo, at its option, will either repair or replace the item free of charge, if it is returned to Wolo within three months from the date of purchase together with proof of purchase as described below. Wolo reserves the right to inspect any defect prior to settling any warranty claim by repair or replacement. This warranty is limited as above provided and Wolo will not be responsible for fire or other casualty or accident, due to neglect, abuse, abnormal use, modifications, faulty installation of this product, or natural causes.

ANY EXPRESSED WARRANTY NOT PROVIDED HEREIN IS EXCLUDED AND DISCLAIMED. THE IMPLIED WARRANTIES OF MERCHANTABILITY AND OF FITNESS FOR A PARTICULAR PURPOSE ARE EXPRESSLY LIMITED TO A TERM OF THREE (3) MONTHS. UNDER NO CIRCUMSTANCES SHALL WOLO BE LIABLE TO PURCHASER OR ANY OTHER PERSON FOR ANY SPECIAL OR CONSEQUENTIAL DAMAGES, WHETHER ARISING OUT OF BREACH OF WARRANTY OR OTHERWISE.

To obtain warranty service, return the product prepaid, and include the original bill of sale showing the date of purchase. Provide with the return a brief description of the problem. Also, include with the return a check or money order in the amount of \$10.00 to cover return shipping. Mail to:

Wolo Manufacturing Corp.
One Saxwood Street, Deer Park, NY 11729
Attn: Warranty Service
E-mail: tech@wolo-mfg.com