

INSTALLATION INSTRUCTIONS FOR FA-SIREN

Your purchase of a Wolo siren is a perfect choice for your vehicle for both new and replacement applications. Wolo's products are manufactured with the finest materials. Each siren is tested to ensure it meets all manufacturing specifications, before it is packaged. If you need help installing this product, our technicians are available to answer your questions, Monday through Friday from 9 AM to 4 PM EST by calling 1-888-550-HORN (4676).

MOUNTING Fig. 1

1. LOCATE AN AREA IN THE ENGINE COMPARTMENT THAT IS DRY AND SAFE FROM EXHAUST MANIFOLD HEAT. Using the siren's mounting bracket as a template mark hole location and drill to size. Secure the siren to the vehicle using the bracket and hardware provided.

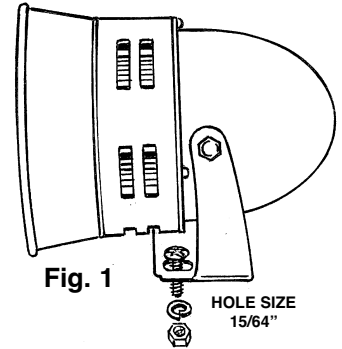

WIRING

Electrical Connections for a New Horn Button Switch: Fig. #2

2. Connect the siren's RED WIRE to (+) 12-volts positive such as, battery, alternator or accessories. Use 18-gauge or heavier wire. **IMPORTANT:** Always make sure that there is a 6-amp fuse used in the circuit to protect the vehicle, (fuse not included). The fuse should never be more than ten-(10) inches from battery or (+) positive connection point.

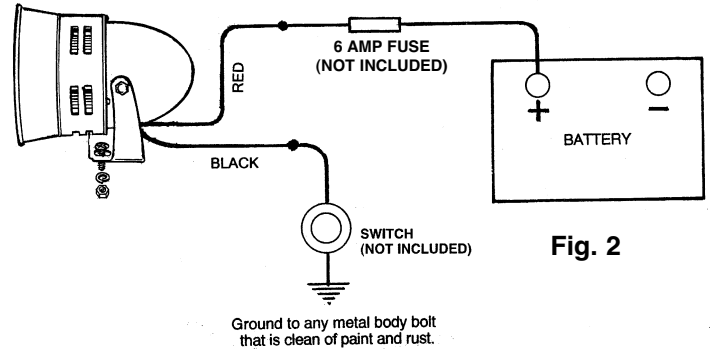

3. Connect the siren's BLACK WIRE to the on/off switch, (switch not included).
4. Connect the other terminal of the on/off switch to ground, any metal body surface that is clean of paint and rust.
5. Installation is complete.

Warranty

Wolo Manufacturing Corporation ("Wolo") warranties to the original purchaser, for three months from the date of purchase, that this product is free from defects in workmanship and materials. If there is such a proven defect, Wolo, at its option, will either repair or replace the item free of charge, if it is returned to Wolo within three months from the date of purchase together with proof of purchase as described below. Wolo reserves the right to inspect any defect prior to settling any warranty claim by repair or replacement. This warranty is limited as above provided and Wolo will not be responsible for fire or other casualty or accident, due to neglect, abuse, abnormal use, modifications, faulty installation of this product, or natural causes.

ANY EXPRESSED WARRANTY NOT PROVIDED HEREIN IS EXCLUDED AND DISCLAIMED. THE IMPLIED WARRANTIES OF MERCHANTABILITY AND OF FITNESS FOR A PARTICULAR PURPOSE ARE EXPRESSLY LIMITED TO A TERM OF THREE (3) MONTHS. UNDER NO CIRCUMSTANCES SHALL WOLO BE LIABLE TO PURCHASER OR ANY OTHER PERSON FOR ANY SPECIAL OR CONSEQUENTIAL DAMAGES, WHETHER ARISING OUT OF BREACH OF WARRANTY OR OTHERWISE.

To obtain warranty service, return the product prepaid, and include the original bill of sale showing the date of purchase. Provide with the return a brief description of the problem. Also, include with the return a check or money order in the amount of \$10.00 to cover return shipping. Mail to:

Wolo Manufacturing Corp.
One Saxwood Street, Deer Park, NY 11729
Attn: Warranty Service
E-mail: tech@wolo-mfg.com