

INSTALLATION INSTRUCTIONS

for Road Warrior DD – Model 845

The addition of a Wolo horn for your vehicle will provide an extra level of sound. The Wolo name, with more than twenty years of experience is your guarantee of a superior horn. Each horn and compressor is bench tested before it is packaged. Precision workmanship and quality components will assure years of reliable service. If you require assistance installing your new Wolo horn, our technicians are available to answer your questions, Monday through Friday from 8 AM to 4 PM EST 1-888-550-HORN (4676).

AIR HORN INSTALLATION

1. Locate the desired area you wish to mount the dual trumpet air horn. For best results, the front of the horn should be unobstructed so that the sound can carry straight ahead.
2. Use the horn's rubber gasket as a template. Mark hole locations and drill to size as shown in Fig. A.
3. Secure the horn with hardware provided. Tighten evenly to provide a good water tight seal. Fig. A.

IMPORTANT: Be sure to use the rubber gasket to protect against water leaks.

4. Position the front trumpet support bracket around the narrow part of the trumpet. Push the bracket forward until it is tight. Use the bracket as a template, mark hole locations and drill to size. See Fig. B.
5. Secure the front trumpet support bracket with the hardware provided.

IMPORTANT: Be sure to use the rubber gasket to protect against water leaks.

6. Secure the flexible inlet hose into the base of the horn. Do not remove the Teflon tape on threaded end of hose. The tape is used to prevent air leaks.
7. Install the tank and the trumpets back onto the horn's base. Only hand tightening is required.

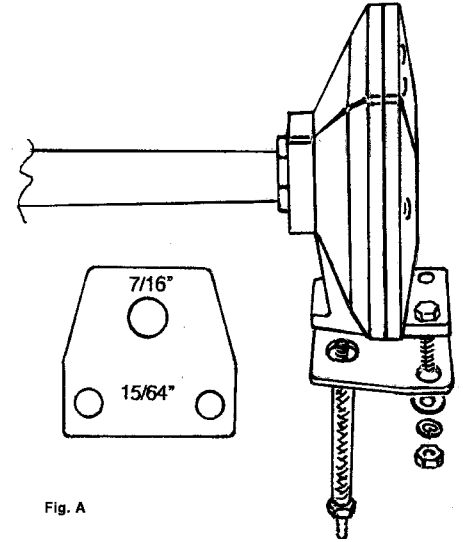
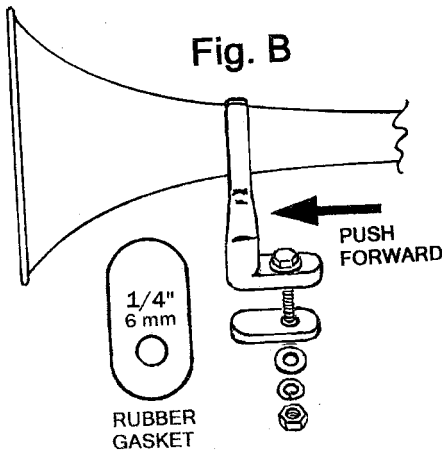

COMPRESSOR INSTALLATION

8. Install the compressor in a dry location. **IMPORTANT:** Compressor must be mounted not further than 8 to 10 inches from the trumpet for proper sound.

9. To secure the compressor drill one 5/16" hole. When possible, mount the compressor (air outlet on top). Install the head of the bolt into the slot on the side of the compressor. Secure the compressor to the vehicle using the lock washer/nut provided as shown in Fig. C.
10. Using the plastic tubing provided, connect the compressor to the horn's flexible inlet hose as shown in Fig. D.

Caution: Avoid making any kinks or sharp bends in plastic tubing that will reduce air flow and alter the horn's sound.

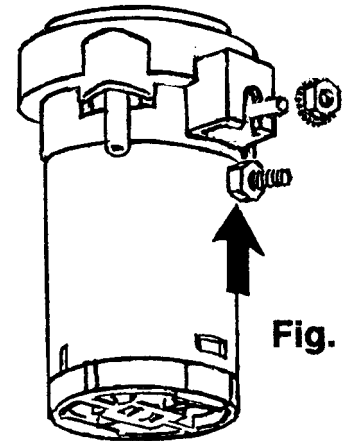

WIRING

11. Electrical Connection – Using Vehicle Factory Wiring

IMPORTANT: You are not required to use the relay supplied with the kit because the vehicle factory system already has a relay.

- A. For two (2) wire systems: If vehicle's factory horn has two (2) terminals, simply transfer wires to the compressor's terminals.

IMPORTANT: when testing the horn if compressor turns on but the horn does not sound, reverse the wires connected to the compressor.

- B. For one (1) wire systems: If vehicle's factory horn has one (1) terminal, simply transfer the wire to the compressor's positive (+) terminal.

- C. Use 16-gauge wire or heavier, the compressor's negative terminal is connected to any metal body bolt. A ground connection should be free of rust and paint.

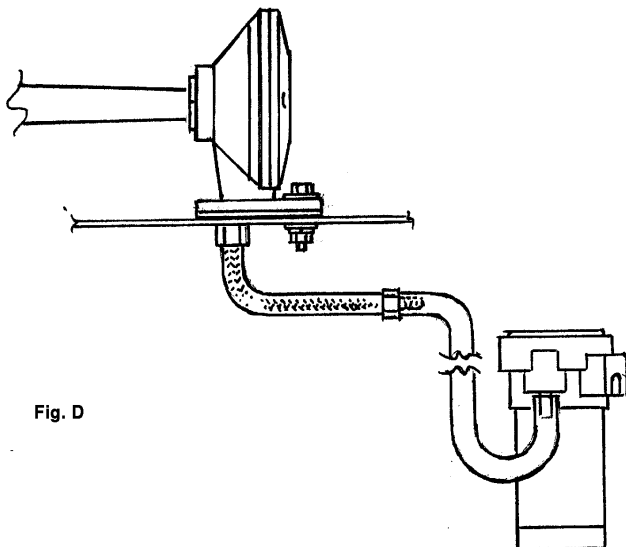
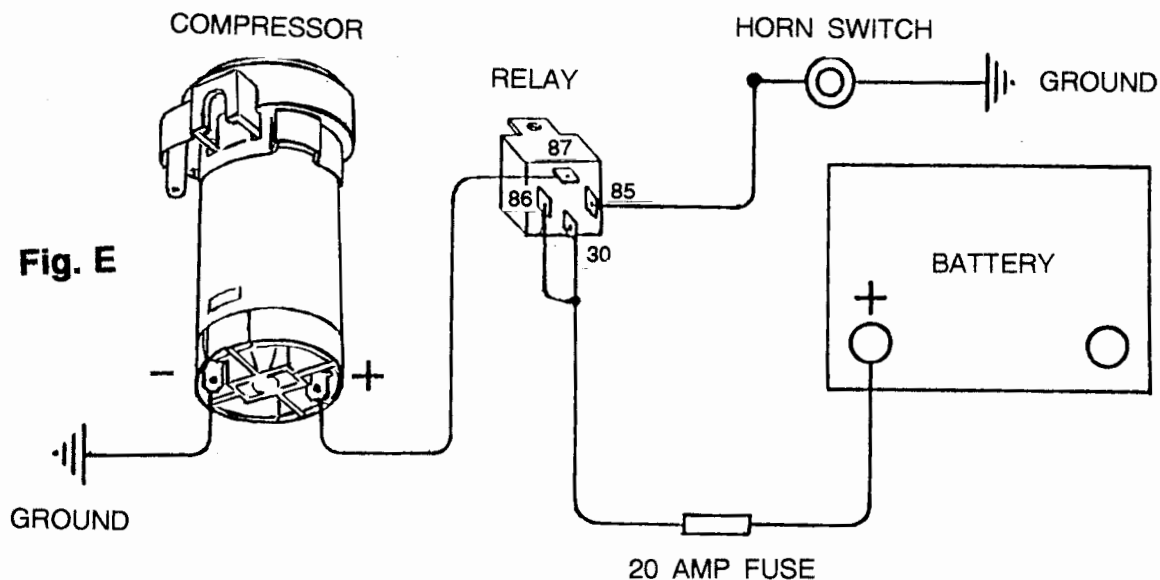

Fig. D

Electrical Connections for a New Horn Button Switch



13. Electrical Connection For A New Horn Button Switch (Included) (See Fig. E)

- A. The relay that is supplied in kit must be used to power compressor. Find a location near the compressor that is dry.
IMPORTANT: Use 16-gauge wire or heavier.
- B. Connect to horn switch terminal (-) ground. (Place a wire under any metal body bolt that is clean of paint and rust.)
- C. Connect the other horn switch terminal to relay terminal #85.
- D. Relay terminal #30 is connected to (+) 12 volts, battery, alternator, etc. The 20 amp inline fuse provided must be used to protect your vehicle.
- E. Relay terminal #86 is connected to relay terminal #30.
- F. Relay terminal #87 is connected to the (+) terminal on the bottom of the compressor.
- G. Ground is connected to the other compressor terminal marked (-). Place a wire under any metal body bolt that is clean of paint and rust.
- H. **Recap of Terminal Connections for New Horn Switch:**
Terminals: 30/86 - the two terminals are connected to 12 volts positive (+) using a fuse.
Terminal: 85 - connect to horn switch negative (-).
Terminal: 87 - connect to positive (+) terminal of compressor.

WARRANTY

Wolo Manufacturing Corporation ("Wolo") warrants to the original purchaser, for three months from the date of purchase, that this product is free from defects in workmanship and materials. If there is such a proven defect, Wolo, at its option, will either repair or replace the item free of charge, if it is returned to Wolo within three months from the date of purchase together with proof of purchase as described below. Wolo reserves the right to inspect any defect prior to settling any warranty claim by repair or replacement. This warranty is limited as above provided and Wolo will not be responsible for fire or other casualty or accident, due to neglect, abuse, abnormal use, modifications, faulty installation of this product, or natural causes.

ANY EXPRESSED WARRANTY NOT PROVIDED HEREIN IS EXCLUDED AND DISCLAIMED. THE IMPLIED WARRANTIES OF MERCHANTABILITY AND OF FITNESS FOR A PARTICULAR PURPOSE ARE EXPRESSLY LIMITED TO A TERM OF THREE (3) MONTHS. UNDER NO CIRCUMSTANCES SHALL WOLO BE LIABLE TO PURCHASER OR ANY OTHER PERSON FOR ANY SPECIAL OR CONSEQUENTIAL DAMAGES, WHETHER ARISING OUT OF BREACH OF WARRANTY OR OTHERWISE.

To obtain warranty service, return the product prepaid, and include the original bill of sale showing the date of purchase. Provide with the return a brief description of the problem. Also, include with the return a check or money order in the amount of \$10.00 to cover return shipping. Mail to:

Wolo Manufacturing Corp. • One Saxwood Street, Deer Park, NY 11729
Attn: Warranty Service
E-mail: tech@wolo-mfg.com