

Installation Instructions for HIGH-PRESSURE COMPRESSOR Model 880-C

Your purchase of a WOLO high-pressure compressor is the perfect choice to power air horns, pneumatic tools and vehicle suspension. The Wolo name, with more than fifty years of experience, is your guarantee of a superior product. If you need help installing this product, our technicians are available to answer your questions, Monday through Friday from 9 AM to 4 PM EST by calling 1-888-550-HORN (4676).

Before installation of the compressor is attempted, it is important to read these instructions completely. The person installing the compressor must have knowledge of the proper method for mounting and securing the compressor to the vehicle and knowledge of the vehicle's electrical system. Again, read this manual completely and note any messages marked "**IMPORTANT**" or "**WARNING**". A safe installation will prevent serious injury or damage to the vehicle.

COMPRESSOR INSTALLATION Fig. 1

IMPORTANT: Make sure that the vehicle's air storage tank has no pressure before attempting to connect the compressor's braided hose.

IMPORTANT: NEVER INSTALL THE COMPRESSOR TO THE AIR TANK THAT CONTROLS THE VEHICLE'S BRAKES OR ANY OTHER CRITICAL OPERATING SYSTEM OF THE VEHICLE.

1. Select a convenient location to mount the compressor that will be dry. If the location is in the engine compartment, make sure the compressor is mounted a safe distance from the exhaust manifold. When possible, mount compressor as far to the front of vehicle as possible so to provide optimum airflow around compressor. **IMPORTANT:** Do not mount the compressor on a plastic fender well, or a flexible surface.
2. Using the compressor's mounting base as a template, mark the location of the four mounting holes and drill to size, 3/16".
3. **IMPORTANT:** Leave enough room to access the two air filters for periodic maintenance. Review step number 5. before mounting the compressor.
4. Secure the compressor to the mounting surface using the hardware provided.

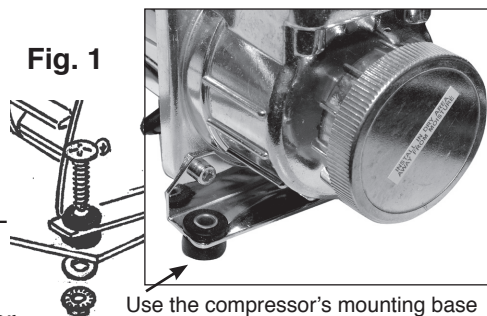

Use the compressor's mounting base as a template to mark the 3/16" holes for drilling

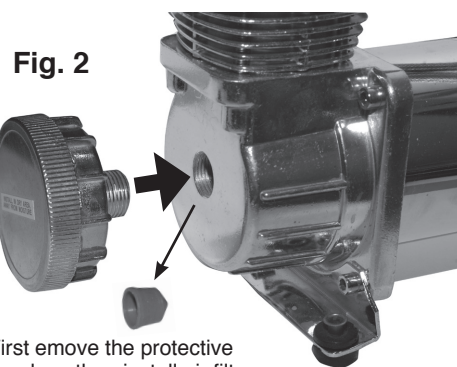

First remove the protective rubber plugs, then install air filters.

AIR FILTER INSTALLATION Fig. 2

5. There are two air filters that are included and need to be installed. The filters are designed to protect each pump from dust, prolonging the compressor life. Remove the rubber plug located in the center of the pump housing. Secure the air filter to the pump housing by turning clockwise until tight. Repeat procedure with the second air filter on the opposite side.

BRAIDED HOSE INSTALLATION Fig. 3

6. Connect one of the compressor's stainless steel braided hoses to tanks' inlet ports. The fitting on the end of the braided hose has been wrapped with Teflon® tape to prevent air leaks, don't remove the tape.

IMPORTANT: There are two-threaded reducer fittings included, if the air tank has 1/4" N.P.T (National Pipe Thread) inlet fittings, you will need to use the reducer fittings. Thread the male end of the reducer fitting to the tanks' inlet port and tighten. Connect the compressors stainless steel braided hose to the reducer fitting and tighten. The fitting on the end of the braided hose is a backflow check valve and the threaded end is wrapped with Teflon® tape to prevent air leaks, do not remove the tape. **WARNING:** Use care not to over tighten fittings.

7. Install the compressor's second braided hose to the tank using the same procedure.

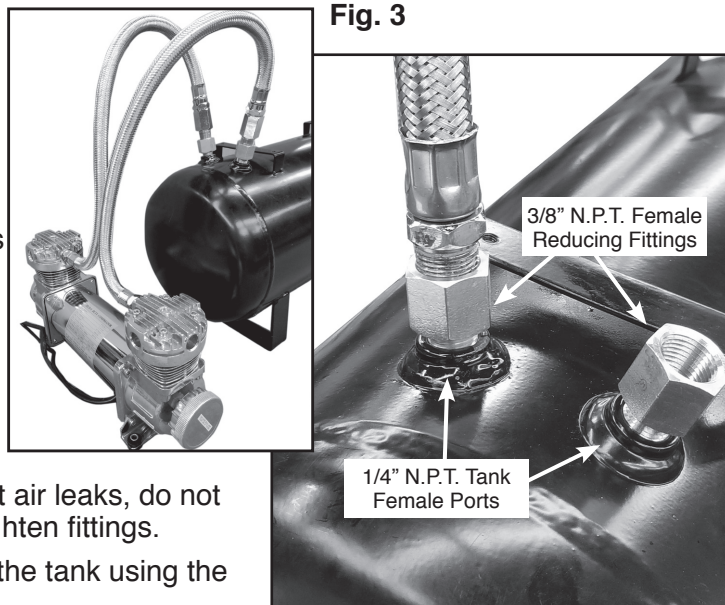

MOUNTING RELAY Fig. 4

- Secure the relay to the mounting surface in a dry location using the mounting bracket and sheet metal screw provided. The dimple on the mounting bracket is positioned against the case of the plug. Slide the the mounting bracket into the plugs slotted side. **IMPORTANT:** Secure the mounting bracket using the sheet metal screw provided. The wires connected to the relay plug should be facing downward which will help prevent water from entering into the case of the relay.

WIRING COMPRESSOR Fig. 5

- Connect the 3-amp inline fuse** provided to a +12-volt power source. **IMPORTANT:** The (+) 12-volt power source must be controlled by the vehicle's ignition switch. This will prevent the compressor from turning on if there is an air leak when the vehicle is not in operation. Suggested electrical connection points are: blower motor, windshield wiper motor and the fuse panel. **CAUTION:** remove the 3-amp fuse from the fuse holder until installation of the compressor is complete. **OPTIONAL:** A switch (not included) can be installed to the 3-amp red fuse wire, this will allow the driver to turn-off the compressor when not required.

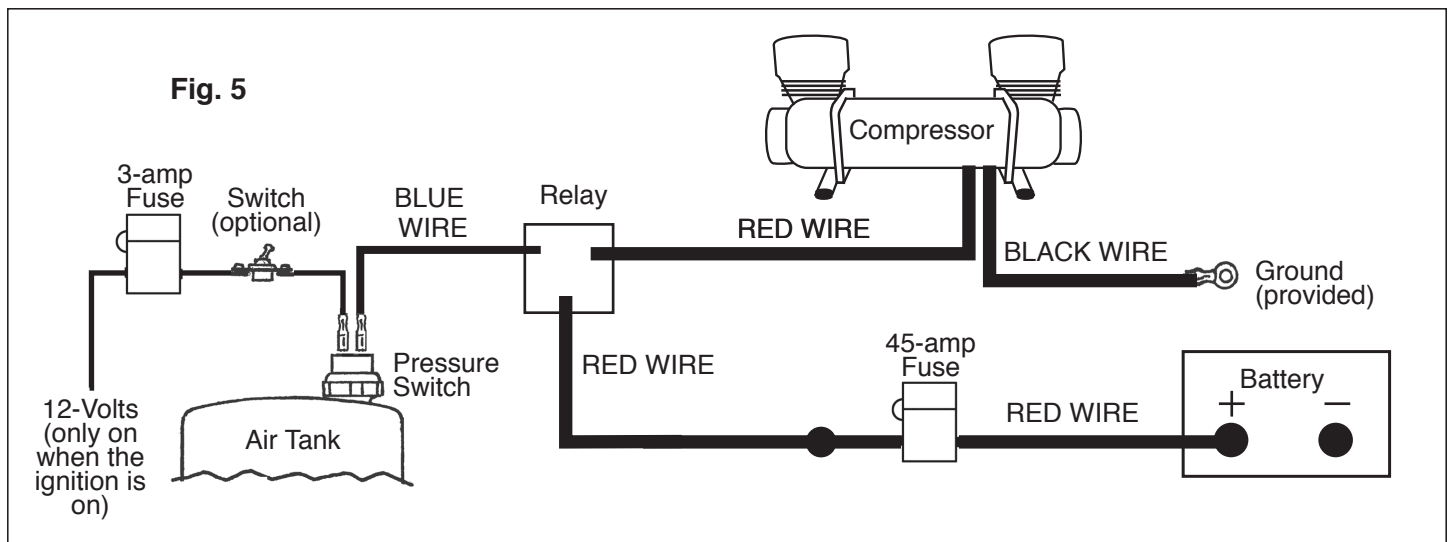
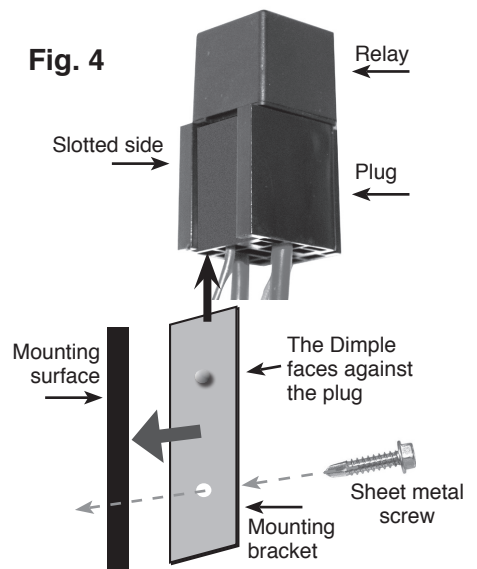

- 3-amp inline fuse:** Connect the 1/4" female terminal to the air system's pressure switch (Pressure switch not included).
- Relay's blue wire:** Connect to the pressure switch's other terminal.
- 45-amp inline fuse:** is connected to (+) 12-volt power source. **IMPORTANT:** The red fused wire must be connected directly to the vehicle's (+) battery post. **CAUTION:** remove the fuse from the fuse holder until installation is complete.
- Compressor's heavy red wire:** is connected to the 45-amp in-line fuse. After terminals are connected together, slide the rubber insulator completely over the terminals.
- Compressor's heavy black wire:** is connected to ground; either the (-) side of the vehicle's battery or under any metal body bolt. Make sure the ground connection is free of rust and paint.
- To prevent shorts in wiring, all connections must be properly insulated with electrical tape or insulated terminals.
- Make sure all wires are securely fastened using plastic wire ties or electrical tape (not provided). **WARNING:** If any wiring was done in the dashboard area, carefully inspect to make sure that there are no wires, cables, etc. that could interfere with the operation of the vehicle's controls: accelerator pedal, brake pedal and clutch pedal.
- Insert both fuses into the fuse holders that they were removed from and the compressor will turn on automatically. Installation is complete.

REFERENCE:

- PURPLE 3-Amp fuse:** Is inserted into the fuse holder that is connected to the pressure switch.
- LIGHT PURPLE 45-Amp fuse:** Is inserted the fuse holder that is connected to the compressor's heavy red wire.

Depending on the pressure switch's (pressure switch not included) on/off specification, when the pressure in the tanks drops below 80 PSI, the pressure switch will automatically turn on the compressor. When the tank pressure is approximately 120 PSI the compressor will automatically turn off. If the compressor does not shut off after 4 minutes of running time, check all fittings and connections for air leaks. Use soapy water or bubble solution on each fitting, while the compressor is pumping. If leak persists after tightening, remove fitting, clean and apply Teflon tape or thread sealant and reinstall fitting.

PREVENTIVE MAINTENANCE:

- Electrical connections should be checked periodically to ensure that they are secure and there is no corrosion.
- The compressor comes with two washable air filters that are accessible by turning the filter housing front cover counter clockwise. It is recommended that the filter be washed and cleaned using a mild liquid soap every 60 days if the environment is dusty. When the filter is clean you will be able to see day light through it, when necessary replace the filter.

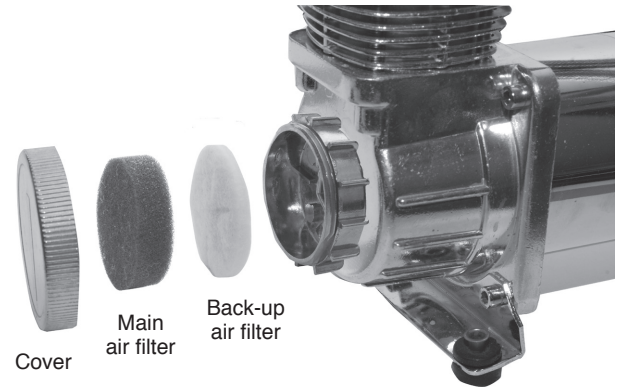

CAUTION: Do not touch compressor or fittings with bare hands during or immediately after usage, the compressor will be hot.

IMPORTANT: The compressor is equipped with an internal THERMAL OVERLOAD PROTECTOR. If compressor should shut off before the tank has been filled to the pressure switch's turn off pressure, do not attempt to restart the compressor. Allow compressor to cool down for approximately 40 minutes before resuming use. The compressor comes from the factory permanently lubricated and the motor is maintenance free. Never attempt to lubricate, modify or service the compressor. Any required repairs must be done by Wolo Manufacturing Corp. or the factory warranty is void

COMPRESSOR SPECIFICATIONS:

12-Volt heavy-duty compressor
Current: 45 amps at peak
CFM: 4.2
Duty cycle 33% @ 100 PSI
In-line fuse holder with 45-amp fuse provided
Permanent magnetic motor that is gearless and thermally protected

Oil-less maintenance free design
High performance piston ring
Moisture & dust resistant
Chrome plated alloy cylinder
Mounting base has four-rubber vibration bushings
Stainless steel braid with pressure check valve

Warranty

Wolo Manufacturing Corporation ("Wolo") warranties to the original purchaser, for three months from the date of purchase, that this product is free from defects in workmanship and materials. If there is such a proven defect, Wolo, at its option, will either repair or replace the item free of charge, if it is returned to Wolo within three months from the date of purchase together with proof of purchase as described below. Wolo reserves the right to inspect any defect prior to settling any warranty claim by repair or replacement. This warranty is limited as above provided and Wolo will not be responsible for fire or other casualty or accident, due to neglect, abuse, abnormal use, modifications, faulty installation of this product, or natural causes.

ANY EXPRESSED WARRANTY NOT PROVIDED HEREIN IS EXCLUDED AND DISCLAIMED. THE IMPLIED WARRANTIES OF MERCHANTABILITY AND OF FITNESS FOR A PARTICULAR PURPOSE ARE EXPRESSLY LIMITED TO A TERM OF THREE (3) MONTHS. UNDER NO CIRCUMSTANCES SHALL WOLO BE LIABLE TO PURCHASER OR ANY OTHER PERSON FOR ANY SPECIAL OR CONSEQUENTIAL DAMAGES, WHETHER ARISING OUT OF BREACH OF WARRANTY OR OTHERWISE.

To obtain warranty service, return the product prepaid, and include the original bill of sale showing the date of purchase. Provide with the return a brief description of the problem. Also, include with the return a check or money order in the amount of \$20.00 to cover return shipping. Mail to:

Wolo Manufacturing Corp. One Saxwood Street, Deer Park, NY 11729
Attn: Warranty Service E-mail: tech@wolo-mfg.com