

# INSTALLATION INSTRUCTIONS FOR ALL MODELS OF WOLO SERIES 3700 PRIORITY 2 WARNING LIGHTS PERMANENT MOUNT

Your choice of a Wolo warning light is the perfect choice to compliment your vehicle. Wolo's warning lights are manufactured with the finest materials. Each light is tested to meet our high standards before it is packaged, to assure a perfect working light. Our quality workmanship and components are Wolo's assurance of a product that will give years of dependable service.

If you need help using your new Wolo warning lights, our technicians are available to answer your questions, Monday thru Friday, from 9 AM to 4 PM EST at 1-888-550-4676.

## MOUNTING

1. Locate the position that the safety warning light is to be mounted. Make sure the light can be seen 360 degrees. Clean the selected location so that it is free from dirt, wax and oil.
2. Remove the lens from the warning light's base by unscrewing the four (4) hex screws, one on each corner of the lens. Carefully separate lens from the base.
3. Position the warning light's base on the selected mounting location Fig. 1. Mark the four (4) mounting hole locations and mark the power wire hole location. Fig. 1. Remove the warning light from the mounting surface.
4. The rubber pad provided will help eliminate vibration and water leaks and has adhesive surface under the peel off paper. (DO NOT PEEL OFF PAPER FROM PAD AT THIS TIME).

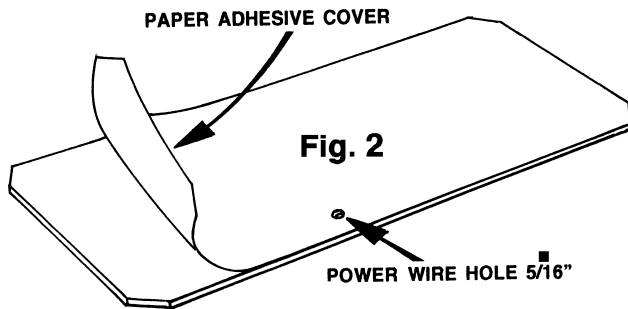
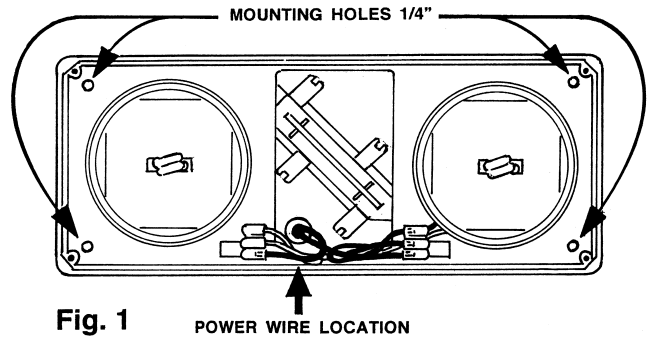

5. Clean the surface area that the light is going to be mounted to, so it is free of dirt, wax and oil.
6. Remove the cut circles in the rubber pad. (Fig. 2)
7. Remove the paper from the rubber pad's surface. Push the power wires through the hole in the pad. Fig. 2. **IMPORTANT:** The adhesive side of the rubber pad is placed against the base of the light. When pad is in position on the base, press firmly on pad for adhesive to secure the pad in place. **NOTE:** make sure the pads four (4) mounting holes line up with the base of the warning light.
8. Drill marked mounting holes and the power wire hole to sizes shown in Figure 1 & 2.
9. Holding the light's base push the power wire through the drilled hole on the mounting surface and position the base over the four (4) drilled mounting
10. Secure the base of the warning light to the vehicle using the hardware provided. To prevent vibration and water leaks, use only the hardware provided by Wolo in this kit and mount only as shown in Fig. 3. **IMPORTANT:** Tighten screws evenly.
11. Secure the lens back in place onto the base. **CAUTION:** Be sure not to over tighten which could crack the lens.

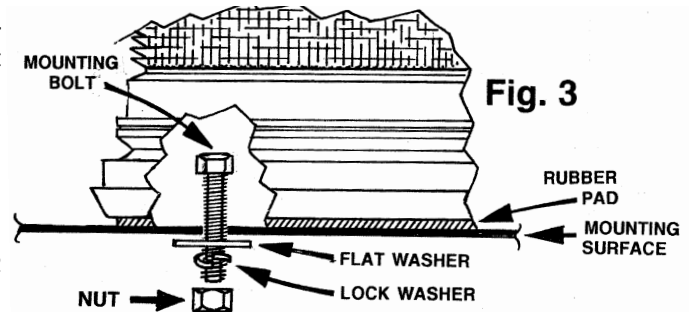

## WIRING

12. Connect the warning light's red wire labeled to (+) 12 volts, battery, alternator, etc. The 10-amps inline fuse provided must be used to protect the vehicle.
13. Connect the other warning light's black wire to your on/off switch. (not provided).
14. Connect the other terminal or wire from the on/off switch to ground, any metal body bolt that is clean of paint and rust.
15. If you should need to lengthen any wires use 18 gauge or heavier. Make sure all wire connections are taped and secured.

## REPLACEMENT BULB

16. **WARNING: HIGH VOLT IS PRESENT IN THE LIGHT STROBE WHICH CAN CAUSE SERIOUS INJURY OR DEATH.** Before attempting to do any service, always disconnect the light from its power source and wait a minimum of ten-(10) minutes before removing the lens and any work is done. A serious injury can result if the bulb is touched when hot. Always wear gloves and eye protection when removing the bulb because the bulb is pressurized and if broken, glass can be projected.
17. Replacement with only with a Wolo 3700RB.
18. Remove the lens by removing the four screws, one screw in each corner of the lens.
19. Remove the outer lens by removing the four screws, one screw in each corner of the lens. Remove the clear inner fresnel lens that has the bulb that needs to be replaced by turning the lens counter clockwise. The lens is secured to the base.

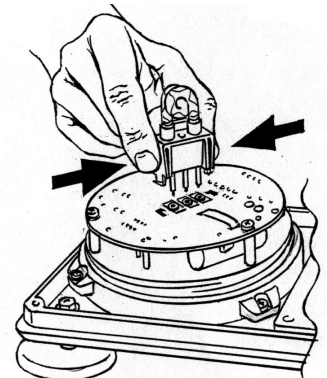

20. The base of the bulb has two tabs, press inward and remove the bulb by lightly pushing the base side to side while lifting upward.
21. Insert the replacement bulb into PC board socket that the bad bulb was removed from and push downward on the bulb's base. Make sure the tabs of the bulb's base engage into the slots of the PC board.
22. Place the clear fresnel lens back into position and secure by turning the lens clockwise until tight.
23. The outer lens is placed back onto the light's base and secured with the four screws. **CAUTION:** to prevent damage or cracking of the lens, tighten screws evenly and do not over tighten.

### **Warranty**

Wolo Manufacturing Corporation ("Wolo") warrants to the original purchaser, for three months from the date of purchase, that the product is free from defects in workmanship and materials. If there is such a proven defect, Wolo, at its option, will either repair or replace the item free of charge, if it is returned to Wolo within three months from the date of purchase together with proof of purchase as described below. Wolo reserves the right to inspect any defect prior to settling any warranty claim by repair or replacement. This warranty is limited as above provided and Wolo will not be responsible for fire or other casualty or accident, due to neglect, abuse, abnormal use, modifications, faulty installation of this product, or natural causes.

ANY EXPRESSED WARRANTY NOT PROVIDED HEREIN IS EXCLUDED AND DISCLAIMED. THE IMPLIED WARRANTIES OF MERCHANTABILITY AND OF FITNESS FOR A PARTICULAR PURPOSE ARE EXPRESSLY LIMITED TO A TERM OF THREE (3) MONTHS. UNDER NO CIRCUMSTANCES SHALL WOLO BE LIABLE TO PURCHASER OR ANY OTHER PERSON FOR ANY SPECIAL OR CONSEQUENTIAL DAMAGES, WHETHER ARISING OUT OF BREACH OF WARRANTY OR OTHERWISE.

To obtain warranty service, return the product prepaid, and include the original bill of sale showing the date of purchase. Provide with the return a brief description of the problem. Also, include with the return a check or money order in the amount of \$20.00 to cover return shipping. Mail to:

**Wolo Manufacturing Corp., One Saxwood Street, Deer Park, NY 11729**  
**Attn: Warranty Service E-mail: tech@wolo-mfg.com**

© 2007 Wolo Mfg. Corp.  
All Rights Reserved.