



GRILL & SURFACE MOUNT LED WARNING LIGHT KIT MODELS 8000-A, 8005-B, 8010-R, 8015-BR & 8020-C 12-24-VOLT INSTALLATION INSTRUCTIONS

Your purchase of Wolo's GRILL & SURFACE mount LED light system is the perfect choice to complement your vehicle's warning lights. This product is manufactured with the finest materials and the latest technology. Each light is tested to meet our high standards, to ensure that all functions work perfectly. Our quality workmanship and components are Wolo's assurance that this product will provide years of dependable service. If you need help using or installing your new Wolo warning light, our technicians are available to answer your questions, Monday thru Friday, from 9 AM to 4 PM EST at 888-550-4676.

Before installation is attempted, it is important to read these instructions completely. The lives of people are dependent on the proper installation. The person installing this light must have knowledge of the proper method of installing warning lights to a vehicle as well as knowledge of the vehicle's electrical system. Again, read this manual completely and note any messages marked "**IMPORTANT**" or "**WARNING**". A safe installation will prevent serious injury or damage to the vehicle.

This warning light is factory pre-wired with waterproof plugs for an easy professional installation that will assure reliable service. This kit comes with two (2) high intensity linear LED clusters and the system has the option to be expanded to a total of four (4) clusters. When expanding to four clusters, only use Wolo's pre-wired cluster kits:

Model 8050-A (2 clusters amber)

Model 8055-B (2 clusters blue)

Model 8060-R (2 clusters red)

Model 8065-BR (1 cluster blue / 1 cluster red)

Model 8070-C (2 clusters clear)

Expansion kits should be available at the store you purchased the Grill and Surface Light Kit, or by calling Wolo at: 800-645-5808 or visiting: www.wolo-mfg.com

Also included in the kit is a control panel, dash mountable with an on/off switch and a push button switch to change the light pattern, all that is required for a successful installation.

Installation of this warning light kit requires drilling to the vehicle. The installer must carefully inspect both sides of any location that will be drilled to ensure that there are no components, wires and or any vehicle parts that could be damaged when drilling.

IMPORTANT: Always de-burr any drilled holes to ensure that there are no sharp edges. Install a rubber grommet into all metal holes that the wires are being routed through. There is a grommet factory installed on the controller wire.

WARNING: Always refer to the vehicle's shop manual for the deployment location of the air bags. Never install the control panel, wires and/or components in the deployment area of any air bag. Improper installation could reduce the effectiveness of the vehicle's air bag system and/or project an object that could cause serious personal injury or death to the driver or passenger. The user/installer assumes all responsibility to properly access a safe mounting location for the switch control panel, so to provide ultimate safety to the driver and passengers inside the vehicle.

The vehicle operator and/or maintenance department should inspect the light system frequently to ensure that all clusters are functioning and are mounted securely to the vehicle.

These installation instructions should always be kept and stored in a safe location so that they can be referred to when information, maintenance or reinstallation is required. Failure to follow all safety precautions and installation procedures as outlined in these instructions, could result in property damage to the vehicle, serious injury or death to you or others.

MOUNTING SWITCH CONTROL PANEL

Using double face tape or screws

TAPE METHOD:

1. Select a mounting location for the control panel that is easy to reach. **WARNING:** Be sure that the switch control panel or its wires will not interfere with air bags or the driver's vision.
2. Using the double-sided foam adhesive tape provided, mount the control panel to selected location. Make sure that mounting surface is free from dust, wax etc. A clean surface is necessary so that double-sided tape will hold properly.

IMPORTANT: THE ADHESIVE HOLDING POWER BECOMES MAXIMUM IN ABOUT 24 HOURS. LIMIT MOVING OR PUTTING PRESSURE ONTO THE SWITCH CONTROLLER UNTIL THEN.

SCREW METHOD (Fig. 1A and 1B)

Remove the control panel's backing plate using a flat tip screwdriver. (Fig.1A)

3. Using the backing plate as a template, mark the two-hole locations onto the mounting surface where the switch panel will be mounted and drill to size using a 3/16" drill (Fig. 1B). **WARNING:** The installer must carefully inspect both sides of the mounting location before drilling any holes to ensure that there are no components, wires and or any vehicle part that could be damaged by drilling.
4. Position the backing plate on the mounting surface and secure using the two sheet metal screws provided that have a countersunk head.
5. The control panel is carefully pushed onto the backing plate (Fig. 1B).

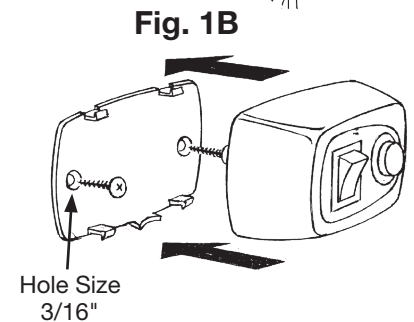
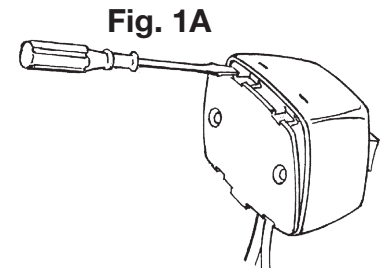

ROUTING SWITCH CONTROLLER WIRE (Fig. 2)

6. The switch controllers 9 ft. wire with the male plug needs to be routed into the vehicle's engine compartment requiring a minimum 1/2" hole. Inspect the vehicle's firewall for access such as rubber plugs or and existing hole.
7. **IMPORTANT:** If drilling a hole is required always de-burr the hole to ensure that there are no sharp edges that can damage the wire. Push the male plug through the firewall.

8. Install the rubber grommet (that was factory installed on the wire) into the drilled hole and slowly pull the wire into the engine compartment.
9. Using the splitter wire that has 1 female plug and 4 wires each having a male plug, connect the splitter's female plug to the switch controllers' wire with the male plug.

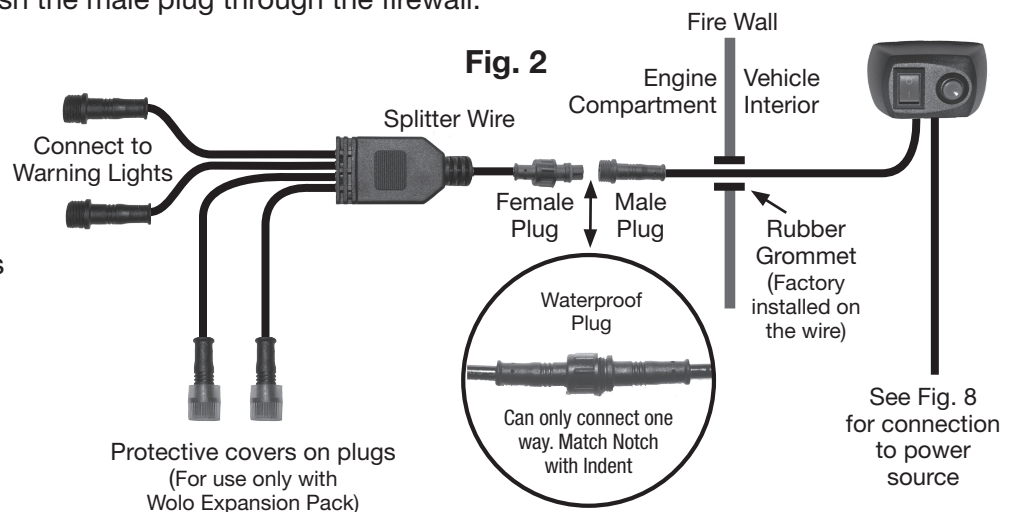

IMPORTANT: You will find that two of the splitter wires have a protective cover on plugs. Do not remove the plug covers unless you purchase an Expansion Pack of 2 additional clusters. The covers are designed to help keep dirt and water out of the plug when not being used.

10. Route the splitter wires with the male plugs to the locations that you plan to mount the LED clusters. (surface or grill mount).

IMPORTANT: make sure the wires will reach the desired mounting location. **Cutting any wires will void factory warranty.**

IMPORTANT: Always make sure that wires are routed away from engine components and hot surfaces to avoid damage to the warning lights wires.

MOUNTING LED CLUSTER

Surface mounting the LED cluster

11. Using the LED mounting bracket as a template, position on the desired mounting surface, and mark the two mounting hole locations and the center wire hole.

NOTE: The mounting bracket will not be used when surface mounting LED cluster, it is being used as a template to mark location where holes will need to be drilled.

- 12. Drill mounting holes to size, see Fig. 3.
- 13. The foam gasket is positioned behind the LED cluster.
- 14. Push the LED cluster wire through the drilled hole.

15. Align drilled mounting holes with the LED cluster and secure using hardware provided. See Fig. 4.

16. Repeat same procedure for second LED cluster.

17. Connect the LED clusters female plug to the splitter wires' male plug.
NOTE: The plugs can only connect in one position. Tighten the shoulder nut fully to ensure a good waterproof connection.

18. Secure all wiring in the engine compartment to be safe from the exhaust manifolds and moving parts.

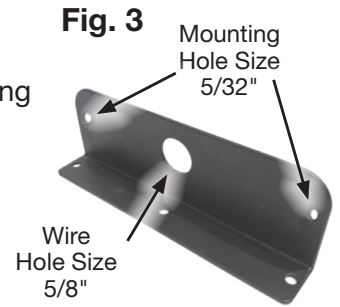
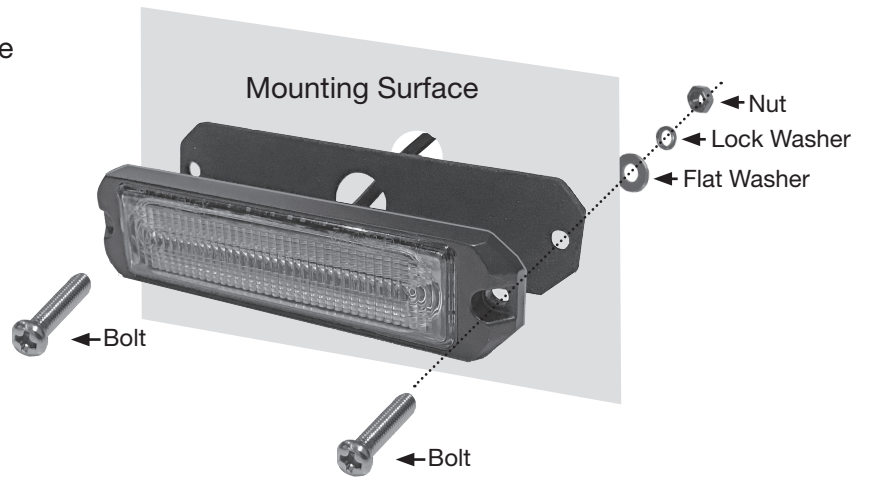

Fig. 4 SURFACE MOUNT



Grill mounting the LED cluster with bracket provided Fig. 5

19. Using the LED mounting bracket as a template, position in grill and mark the mounting hole locations.

20. Drill mounting holes to size see Fig. 5

21. Mount the LED cluster to the mounting bracket using the hardware provided. Make sure that the foam gasket is in position between the bracket and the LED cluster. See Fig. 6.

22. The mounting bracket is secured to the grill using the hardware provided. Repeat same procedure for second bracket.

23. Connect the LED clusters female plug to the splitter wires' male plug.
NOTE: The plugs can only connect in one position. Tighten the shoulder nut fully to ensure a good waterproof connection. See Fig. 7.

Fig. 5

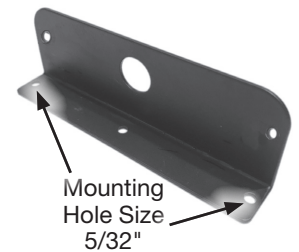
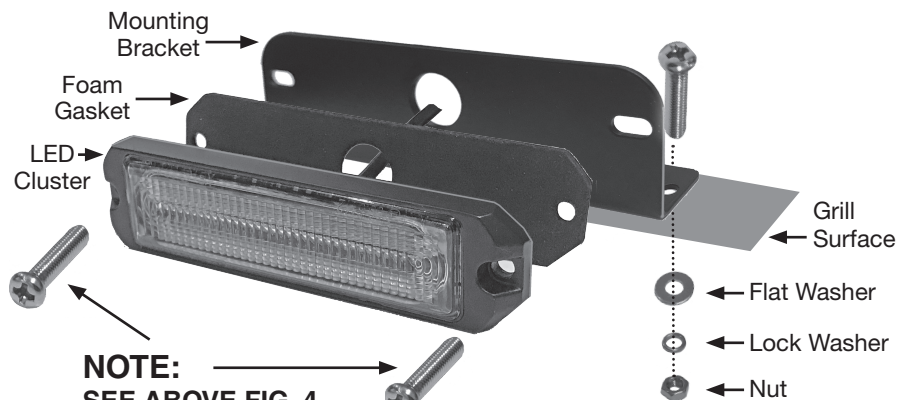

Fig. 6 GRILL MOUNT



NOTE: SEE ABOVE FIG. 4 FOR MOUNTING HARDWARE USED TO SECURE LED CLUSTER TO BRACKET

Fig. 7



Can only connect one way. Match Notch with Indent

WIRING (Fig. 8)

24. Connect the warning light's red wire to (+) 12-volts, battery, alternator, fuse block, etc. The connection must be free of oxidation and rust.

IMPORTANT: The 3-amp inline fuse provided must be used. Connect the fuse within 6" of the power source to properly protect the vehicle.

25. Connect the warning light's black wire to ground, any metal body bolt that is clean of paint and rust.

INSTALLATION IS COMPLETE

26. Position the on/off switch to ON. Press and release the red push button to change the light pattern.

CHANGING LIGHT PATTERN:

There are twenty-six (26) different light patterns to choose from. Press and release the red button on the switch controller and the light pattern will change.

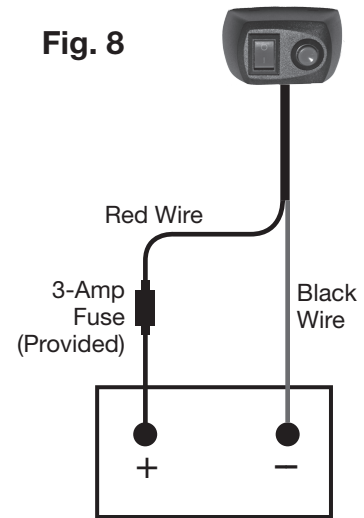

Warranty

Wolo Manufacturing Corporation ("Wolo") warrants to the original purchaser, for three months from the date of purchase, that this product is free from defects in workmanship and materials. If there is such a proven defect, Wolo, at its option, will either repair or replace the item free of charge, if it is returned to Wolo within three months from the date of purchase together with proof of purchase as described below. Wolo reserves the right to inspect any defect prior to settling any warranty claim by repair or replacement. This warranty is limited as above provided and Wolo will not be responsible for fire or other casualty or accident, due to neglect, abuse, abnormal use, modifications, faulty installation of this product, or natural causes.

ANY EXPRESSED WARRANTY NOT PROVIDED HEREIN IS EXCLUDED AND DISCLAIMED. THE IMPLIED WARRANTIES OF MERCHANTABILITY AND OF FITNESS FOR A PARTICULAR PURPOSE ARE EXPRESSLY LIMITED TO A TERM OF THREE (3) MONTHS. UNDER NO CIRCUMSTANCES SHALL WOLO BE LIABLE TO PURCHASER OR ANY OTHER PERSON FOR ANY SPECIAL OR CONSEQUENTIAL DAMAGES, WHETHER ARISING OUT OF BREACH OF WARRANTY OR OTHERWISE.

To obtain warranty service, return the product prepaid, and include the original bill of sale showing the date of purchase. Provide with the return a brief description of the problem with a daytime telephone number. Also, include with the return a check or money order in the amount of \$20.00 to cover return shipping.

Mail to:

Wolo Manufacturing Corp.
Attn: Warranty Service
One Saxwood Street, Deer Park, NY 11729
E-mail: tech@wolo-mfg.com